

FOCUSSING ENERGY REALISING VISIONS

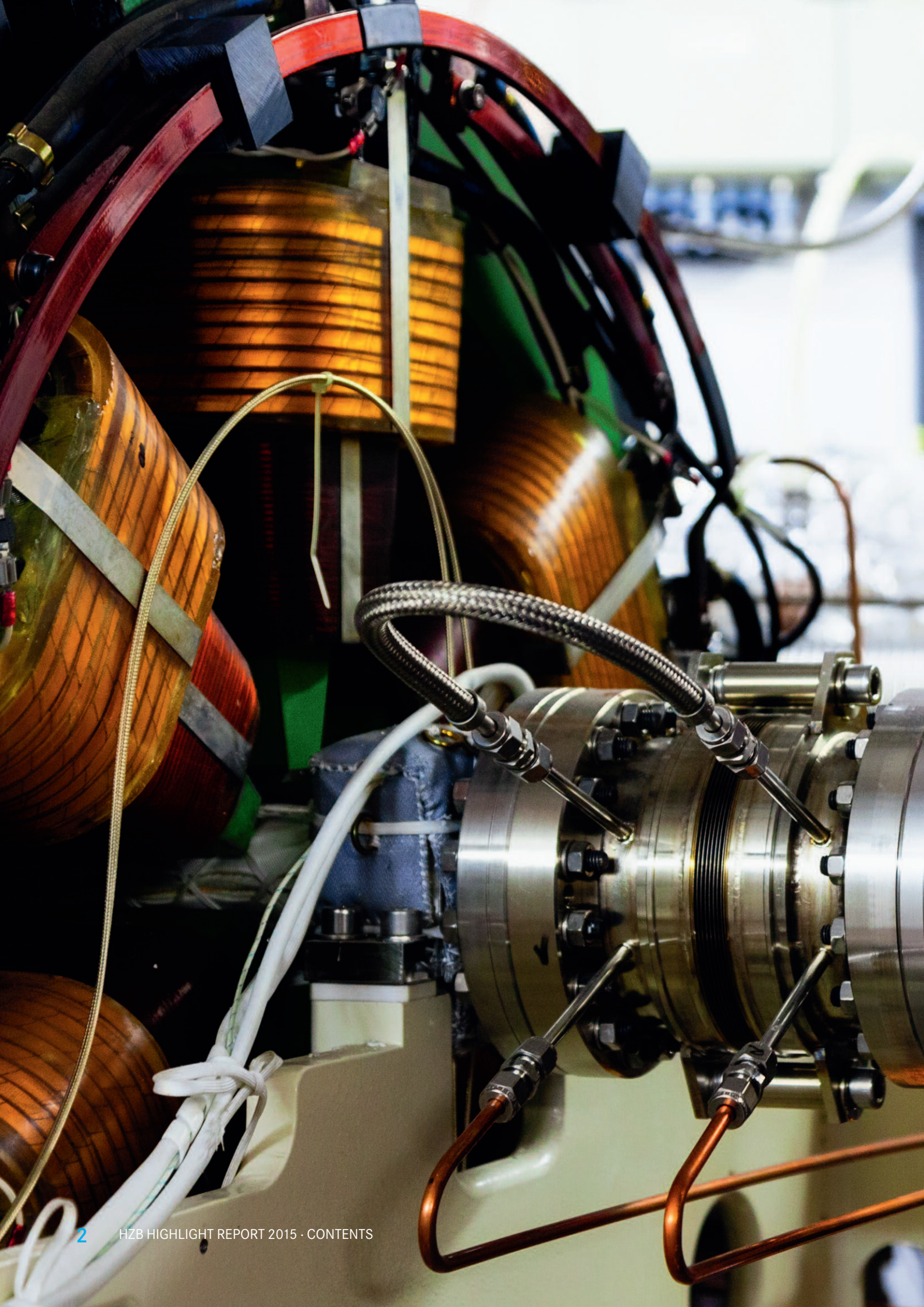

# HIGHLIGHTS 2015

Research highlights at the Helmholtz-Zentrum  
Berlin für Materialien und Energie





## CONTENTS

<b>Foreword</b>	<b>04</b>	The trail is blazed for tender X-rays	32
Future Review Panel supports the strategy of HZB	06	How to flow ultrathin water layers	34
		Specific pulse selection at BESSY II	35
<b>Energy materials research</b>	<b>08</b>	<b>Accelerator research and development</b>	<b>36</b>
Hedgehog and anti-hedgehog for the spin filter	10	Accelerator physicists are looking to Berlin	37
Magnetic patterns to be mapped in 3D	11	Costly magnetic troublemakers	38
New class of materials for organic electronics	12	BESSY II gets second lane	39
How nanoparticles improve efficiency of solar cells	13	<b>Highlights from user experiments</b>	<b>40</b>
An alternative to platinum in catalysts	14	Experiments at up to 26 teslas	41
Mixed crystals in the crystal	16	A “devil’s staircase” in a spin-valve system	42
Depletion and enrichment of chlorine	17	Luminous hybrid	43
Nanoparticles make for better solar cells	18	A microbattery under the X-ray microscope	44
New lab for the research of energy materials	20	Neutron images of hydrogen stores	46
Whispering gallery modes for the light	21	What makes catalysts efficient?	47
Tandem solar cell achieves record efficiency	22	Better batteries with nanopores	48
Industrial partners – analysing solar modules	24	Little helpers for water electrolysis	49
Solar modules hidden in display screens	25	Going for the achilles heel of HIV	50
Efficiency record for artificial photosynthesis	26	Intracellular heavy transport	52
Characterising microstructures in polycrystalline materials	27	Metal oxide sandwiches	53
HEMF: new Helmholtz laboratory infrastructure	28	An enzyme catalyst for carbon dioxide	54
HZB strengthens catalysis research	29	<b>Miscellaneous/Appendix</b>	<b>55</b>
<b>Developing methods for research with soft X-rays</b>	<b>30</b>	Miscellaneous	55
Filming changes within materials	31	HZB Organisation Chart	58
		Site map, imprint	59

---

## HZB IS DEDICATED TO ENERGY MATERIALS RESEARCH

Hardly any issue is as fundamentally important to our society as a safe, reliable and sustainable energy supply. HZB has therefore adopted a strategy to become a leading centre for research into energy materials. The photon source BESSY II plays a key role in all this. HZB plans to upgrade BESSY II into BESSY-VSR, a unique storage ring offering photon pulses of variable length.

**E**nergy materials refers to more than just solar cells that produce electricity from sunlight. Based on its existing competences, HZB has defined a whole series of material systems to include in its future research portfolio. Solar fuels, thermoelectric materials and topological insulators are just a few of them. These are materials that store or convert energy, or which can be used to develop new and energy-efficient information technology.

The recurring theme in HZB's research is thin-film technology. We are forever expanding our expertise in existing thin-film photovoltaic systems, enriching our research with a wide range of analytical methods, on the large facilities especially, and with material synthesis and theory-based simulations. We present a few examples of successful research into such material systems in this issue of our annual Highlight Report, with a new layout this time: Research into energy materials is a big part of this, and shows how diversified in this field HZB has become.

Other chapters in the Highlight Report – we have made visible to which research topic the individual articles can be allocated – cover the development of research methods based on soft X-rays – developments on the BESSY II instrumentation in particular – and research into accelerator technologies. Here you can read up on the progress of our future projects BESSY-VSR – the upgrading of BESSY into a variable-pulse-length storage ring – and bERLinPro – the



Prof. Dr. Anke Kaysser-Pyzalla and Thomas Frederking.

**“The in-house research at HZB is in close connection between energy materials research and the use and evolution of the photon source BESSY II. HZB’s approach is the culmination of a complex strategic process.”**

prototype of an energy recovery linear accelerator. Both projects are aimed at securing HZB's future as a unique location for photon-based research.

This triad of in-house research is reflected in the close connection between energy materials research and the use and evolution of the photon source BESSY II. HZB's approach is the culmination of a complex strategic process which deserves its own double page story in this Highlight Report. Read more on pages 6 and 7 about how the HZB strategy was born and what exactly it involves.

As always, the new Highlight Report format includes articles on our users' experiments. The research examples presented here prove that the users' topics are as wide-ranging as ever, and are not limited to the field of energy

materials. We know that soft X-rays, the speciality of BESSY II, are in high demand in the scientific community. It gives us great pleasure, therefore, to keep them available to all fields of research. That means the Scientific Selection Panel will continue to select applications for beamtime at BESSY II and BER II purely according to the scientific quality of the applications.

**“We know that soft X-rays, the speciality of BESSY II, are in high demand in the scientific community. It gives us great pleasure, therefore, to keep them available to all fields of research.”**

We hope you enjoy reading through our Highlight Report 2015, and direct your attention to the large-format photos illustrating the research highlights. These photos were taken during the Science

Photowalk 2015, the second hosted by HZB since 2012. In our “miscellaneous” section, starting on page 55, you can read more about this and other events at HZB, about awards and distinctions that our researchers have earned

for their outstanding scientific work, and about high-profile appointments and two fellows who came to Berlin in 2015 and who are now enriching the research at HZB.

We would also love to hear what you think about our redesigned Highlight Report and look forward to your feedback!



Prof. Dr. A. Kaysser-Pyzalla  
Scientific Director

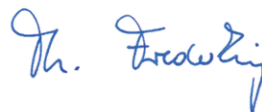

Thomas Frederking  
Administrative Director

---

## FUTURE REVIEW PANEL SUPPORTS THE STRATEGY OF HZB

HZB is sharpening its profile. In tackling urgent social issues such as the energy transition, it has identified strategic fields of action and definite targets to pursue. Its future focus will be **research into energy materials**. Keys to success are the planned expansion of BESSY II into a variable-pulse-length storage ring and new laboratories for the international research community at the Lise-Meitner-Campus in Berlin-Wannsee.

**F**or HZB, the final shutdown of BER II on 31 December 2019 will be a challenge but also an opportunity to strategically redevelop its research portfolio. The action plans, aims and measures are summarised in the HZB Strategy 2020+. HZB's future activities will have a dual focus, on researching with and for new materials in energy-related systems, and on operating and improving its photon source BESSY II. This includes developing a next-generation light source. Both strategic aims are inextricably linked. Other important priorities for HZB are the international integration of the centre, the stronger cooperation with universities and institutes, and the knowledge and technology transfer with industry and society.

HZB is concentrating on energy materials research – in particular functional thin-film systems. These systems are suitable for the future production of solar fuels, for example, or development of spintronic components for more energy-efficient data storage. We worked out this strategic alignment in a lengthy process. First, management talked openly with the centre's researchers in workgroups and workshops. Questions asked included: "In what areas do we have unique selling points? Who are our competitors, and what are our special competencies?" The answers were all consolidated into theme-based strategy papers, which were then discussed again with the internal and external bodies of the centre.

### Building on our own strengths

In the course of the strategic process, the many existing strengths of HZB became clear. In energy materials research, HZB has key competencies in the production and analysis of thin-film systems for energy applications. We are researching into a broad range of materials and developing tailored systems and modules in this field. Our core competencies lie in the development and application of unique, *in-situ* and *in-operando* characterisation methods using vacuum ultraviolet (VUV) and soft X-rays at BESSY II. The strategic process also revealed that we must strengthen our expertise in materials synthesis. From this, it followed that we need to increase our activities relating to the theory and simulation of energy materials. This theoretical basis improves our understanding of the fundamental principles in these materials. In subsequent synthesis steps, incorporating a combined material synthesis and simulation approach, we will have a greater capability in developing tailored energy materials. This process chain ends with the design and development of industrially relevant prototypes.

HZB has unique infrastructures at its disposal for these tasks. Our photon source BESSY II, with its emphasis on VUV and soft X-rays, is excellently suited to the analysis of thin-film systems. In order to capture the dynamics of these materials at higher temporal resolution, we are planning to

### EXCELLENT PROSPECTS

The shareholders of HZB, the Federal Government and the State of Berlin commissioned a Future Review Panel (FRP) to assess the development of HZB since the fusion of the Hahn-Meitner-Institut and BESSY GmbH into Helmholtz-Zentrum Berlin, as well as its future alignment, and to formulate recommendations. The decision to engage this Future Review Panel was already made during the fusion process in 2008.

The conclusion after the review in 2015: the Future Review Panel was highly impressed with HZB's development in the six years since its founding. The FRP shared HZB's visions for its future strategic alignment and encouraged HZB to continue its present course. "The close coupling of energy research and BESSY II offers unique opportunities for research, and is explicitly advocated by the FRP. In particular, the possibilities for time-resolved measurements that will exist with the development of the variable-pulse-length storage ring (BESSY-VSR) are of great interest for energy research."



The supervisory board has supported the strategy process at HZB (l to r): Dr. Antje Niemann, Thomas Frederking, Dr. Olaf Schwarzkopf, Prof. Dr. Anke Kaysser-Pyzalla, Kerstin Görlitz, Prof. Dr. Uschi Steigenberger, Elsbeth Lesner, Dr. Jutta Koch-Unterseher, Jörn Beckmann, Prof. Dr. Beatrix Vierkorn-Rudolph, Prof. Dr. Joachim Treusch, Dr. Karl Eugen Huthmacher, Prof. Dr. Sabine Seidler, Prof. Dr. Peter Fratzl, Prof. Dr. Susann Schorr, Dr. Michael Stötzel and Esther Dudzik.

upgrade BESSY II into BESSY-VSR. The abbreviation VSR stands for “Variable-pulse-length Storage Ring”. It will simultaneously produce both extremely short and relatively long light pulses: Researchers will be able to “switch” freely between them depending on which pulse length they need for their experiments. “BESSY-VSR will be a top-class scientific facility. No other photon source can offer researchers this flexibility and these possibilities for energy materials research,” says Prof. Dr. Anke Kaysser-Pyzalla, scientific director of HZB. BESSY-VSR enjoys widespread acceptance within the Helmholtz Association and among external bodies alike. All experts consider the expansion highly worthwhile. “Accelerator research at HZB’s photon sources attracts worldwide attention,” says Kaysser-Pyzalla.

#### First conceptual considerations for BESSY III

HZB has successfully placed BESSY-VSR on the Helmholtz road map for large infrastructures, and submitted the project into the Helmholtz Association’s selection process for strategic expansion investments. Thomas Frederking, commercial manager of HZB, stresses: “To ensure timely realisation, we have significantly stocked up our own financial contribution. In the best case, and with active support from all employees in the centre, BESSY-VSR will go online in 2020.” Concurrently with the building of BESSY-VSR, the beam tubes and end stations will be optimised for researching into energy materials. This will make them even more attractive for our focal topics and to external users. Preliminary concepts are also already being developed for a successor facility. In the medium term, the VUV and soft X-ray

user community will need a next-generation light source. HZB has already successfully placed such a light source (BESSY III) on the Helmholtz road map for large infrastructures, and has decided to submit this facility as a proposal for the next call for tenders of the National Roadmap for Research Infrastructures of the Federal Ministry for Education and Research. The VUV and soft X-ray range of BESSY III at HZB, the terahertz and infrared range of the planned DALI source at Helmholtz-Zentrum Dresden-Rossendorf, and the hard X-ray range of the planned PETRA IV source at DESY will complement one another optimally.

#### In 2020, HZB will be a preferred venue for users

Other important laboratory infrastructures for energy materials research are already being established at the Lise Meitner Campus in Wannsee: for example, the ZEISS Lab@location with the most advanced electron microscopes and large laser laboratories (see page 27 for more details). Like BESSY II and BESSY-VSR, these laboratory complexes will also be available to external users, increasing the attractiveness of the Wannsee campus to guests from all around the world. Kaysser-Pyzalla is convinced that, “in 2020, HZB will be a preferred venue for the international user community for top-class energy materials research and for the operation of the photon sources BESSY II / Bessy-VSR. Ideally, in 2020+, the first industrially produced prototypes for energy conversion and storage will originate from HZB. By 2030, HZB will have a worldwide leading role in energy materials research focussing on thin-film systems.”

*Roland Steitz and Olaf Schwarzkopf*

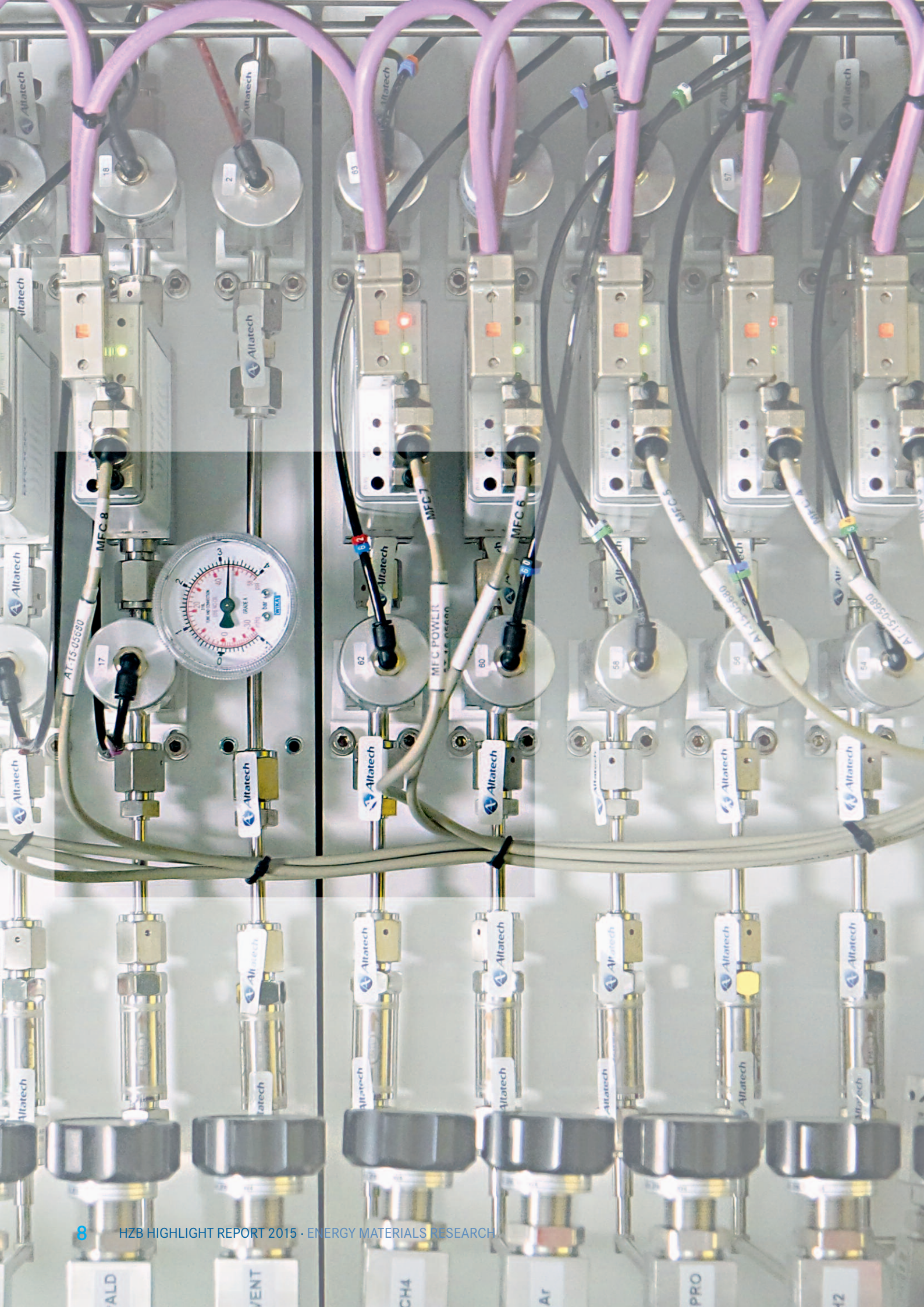



# ENERGY MATERIALS RESEARCH

**75 cooperative partnerships** were initiated between HZB and companies in 2015, 13 of which were with inter-national partners. At the end of 2015, HZB was involved in 113 industrial cooperative projects, 26 per cent of which were partnerships with companies from other countries.

**8 patents** were granted to HZB by the German Patent and Trade Mark Office in 2015. At the end of 2015, HZB's patent portfolio included 289 national and international property rights, 203 of which were patents granted. 26 property rights were objects of ongoing licence agreements.

**74 new partnerships** were initiated between HZB and scientific institutions in 2015, 27 of these being with international partners. In total, there were 231 scientific cooperative partnerships at the end of 2015, of which 41 per cent were projects with partners from other countries.

The new **Energy Materials In Situ Laboratory EMIL** is now online after the successful acceptance phase, installation and commissioning of the analytical hardware, and installation and commissioning of the deposition, sample transfer and analysis systems. The first test measurements with laboratory light sources have already been completed. Once the two insertion devices and corresponding beam guides have been installed in the storage ring BESSY II, EMIL will be available for full user operation in 2017.

The "**Helmholtz Energy Materials Foundry (HEMF)**" is conceived as a cross-centre Helmholtz research infrastructure and a dedicated international user platform in the field of energy research. HEMF's scientific focus is on solar fuels, solar cells, fuel cells, battery systems, and thermo-electric and thermochemical materials. The six centres involved in the project in the Helmholtz Association's Energy research field are FZJ, HZB, HZG, HZDR, KIT and DLR. HZB is responsible for their coordination. The project has a total volume of 35.4 million euros.

## HEDGEHOG AND ANTI-HEDGEHOG FOR THE SPIN FILTER

In experiments at BESSY II, HZB scientists have discovered more about the **behaviour of spins in graphene**. Their findings are an important step closer to the lossless conduction of spin currents.

**H**ZB researchers have been experimenting for quite some time with graphene, a material famous for its highly mobile electrons. Their aim is to impose an additional property on graphene: a coupling between the direction of motion of its electrons and their angular momentum, or spin. This coupling, however, is an exclusive property of heavy elements, for example gold. Graphene consists of carbon and is too light for it to work. Yet HZB researchers are experts in depositing gold atoms beneath a graphene layer in a controlled fashion. Doing so allows one to create peculiar spin textures which have become known as the “Rashba effect”. Until recently, only spin textures within the graphene plane had been possible. Now, Dr. Andrei Varykhalov and co-workers have succeeded in turning the spin out of the plane.

### Hedgehog and anti-hedgehog

They achieved this by turning the spin successively out of the plane towards the surface normal, an arrangement much like the spines of a hedgehog. The researchers verified this using spin-resolved photoelectron spectroscopy at BESSY II. Such hedgehog structures are in fact known in nuclear physics, for example. They are singular points which, in principle, would violate the prohibition of magnetic monopoles according to Gauss. Here, Varykhalov remarks that in graphene, everything is doubled because its honeycomb-type crystal structure consists of two equivalent atomic lattices. Indeed, the hedgehog also has a kind of anti-hedgehog, and both together comply with the monopole prohibition.

### Design of a spin filter

The fact that both hedgehog and anti-hedgehog cancel each other out does not mean they have no physical consequences, quite the contrary, explains Prof. Oliver Rader, head of the department. In fact, in their study, the physicists proposed a spintronic device which uses the hedgehog structure to create a highly efficient spin filter. In this spin filter, the spins are deflected to the left and right, respectively. The resulting spin current is in principle

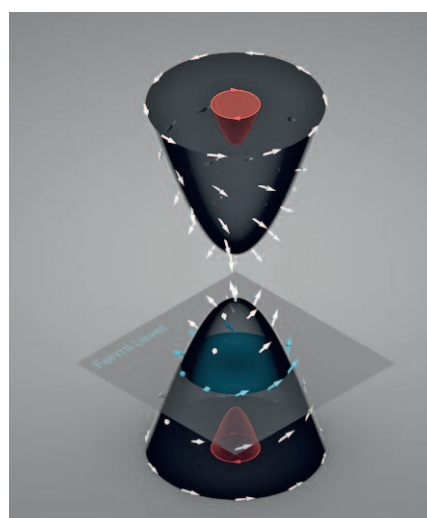

The illustration shows how spins spin out of a plane at the energy surfaces of electrons in reciprocal space. This produces a configuration reminiscent of the spines of a hedgehog.

lossless and could in future reduce power consumption in information technology.

The effect observed in the graphene in the HZB experiments had been predicted by a group from Budapest a few years earlier. Andros Kormányos explains that hedgehog and anti-hedgehog had already been present in the graphene systems previously realised. However, they were inseparably superimposed. Only by breaking the sublattice symmetry, which Varykhalov achieved by choosing a substrate crystal of lower symmetry, could the hedgehog be separated from the anti-hedgehog. Thus they have taken an important step towards building a spin filter.

*arö*

Nature Communications, 6:7610 (DOI: 10.1038/ncomms8610): Tunable Fermi level and hedgehog spin texture in gapped graphene; A. Varykhalov, J. Sánchez-Barriga, D. Marchenko, P. Hlawenka, P.S. Mandal and O. Rader

Phys. Rev. B 83, 155439 (2011), (DOI: 10.1103/PhysRevB.83.155439): Effect of sublattice asymmetry and spin-orbit interaction on out-of-plane spin polarization of photoelectrons; P. Rakyta, A. Kormányos and J. Cserti

## MAGNETIC PATTERNS TO BE MAPPED IN 3D

An international collaboration of scientists has succeeded in using synchrotron light to detect and record the **complex 3D magnetisation** in wound magnetic layers. This technique could be important for medical diagnostics.

**3**D structures in materials and biological samples can be investigated today using X-ray tomography. This is done by recording images layer-by-layer and assembling them on a computer into a three-dimensional mapping. But so far there has been no comparable technique for imaging 3D magnetic structures on nm length scales. Now teams from HZB and the Institut für Festkörperphysik at the Technische Universität Dresden in collaboration with research partners from the Advanced Light Source at the Lawrence Berkeley National Laboratory and the University of California in Santa Cruz have developed a technique with which this is possible.

### Using XPEEM and slightly rotated samples

They studied the magnetisation in rolled-up tubular magnetic nanomembranes (nickel or cobalt-palladium) about two layers thick. To obtain a 3D mapping of the magnetisation in the tubes, the samples were illuminated with circularly polarised X-rays. Using the X-ray microscope at the Advanced Light Source and the X-ray Photoemission Electron Microscopy (XPEEM) beamline at BESSY II, the samples were slightly rotated for each new image so that a series of 2D images was created. “The polarised

light penetrated the magnetic layers from different angles. Using XPEEM, we were not only able to measure the magnetic features at the surface, but we also obtained additional information from the “shadow”, explains Florian Kronast, who is responsible for the XPEEM beamline at HZB.

### 3D reconstruction of magnetic patterns

In the end, the physicists were successful in reconstructing the magnetic features on the computer in three dimensions. “The samples displayed structures not smaller than 75 nanometres. But with this method we should be able to see even smaller structures and obtain a resolution of 20 nanometres”, explains Florian Kronast. However, so far only electron holography could be considered for mapping magnetic domains of three-dimensional objects at the nanometre scale. This required very complicated sample preparation and the magnetisation could only be indirectly determined through the resulting distribution of the magnetic field. “Our process enables you to map the magnetisation directly in 3D. Knowledge of the magnetisation is a prerequisite for improving the sensitivity of magnetic field detectors.”

The new method could be of interest to scientists and developers involved with extremely small magnetic features within small volumes, such as those developing more sensitive devices for medical imaging, for example. Procedures such as magnetoencephalography depend on externally detecting very weak magnetic fields created by the electrical activity of individual nerve cells – using appropriately sensitive detectors.

*arö*

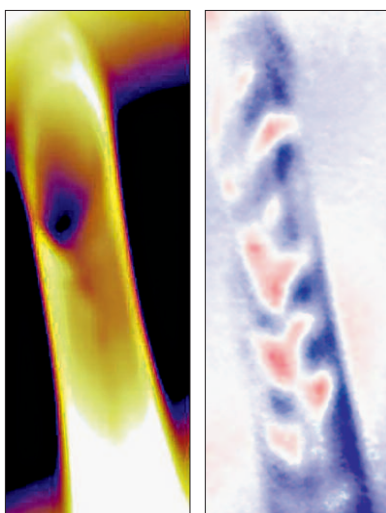

Mapping of the captured magnetisation domains (right, red-blue patterns) in a sample 20 nanometres thick that had been wound in two layers into a tube. The tube has a diameter of 5 microns and a height of 50 microns.

Nature Communications 6, 7612, (DOI: 10.1038/ncomms8612): Retrieving spin textures on curved magnetic thin films with full-field soft X-ray microscopies; R. Streubel, F. Kronast, P. Fischer, D. Parkinson, O. G. Schmidt and D. Makarov

## NEW CLASS OF MATERIALS FOR ORGANIC ELECTRONICS

A cooperative between researchers of HZB, the University of Rostock, Freie Universität Berlin and other partners has figured out how **charge transport works in polymeric carbon nitrides**. These could make low-cost photocatalysts that promote the splitting of water with sunlight.

**P**olymeric carbon nitrides are organic compounds synthesised to form a myriad of nanocrystals in a typically yellow powder. The crystalline structure resembles that of graphite because the carbon nitride groups are chemically bound in layers, while only weak Van der Waals' forces provide cohesion between these layers. It was already known that light is able to create an electron-hole pair in this class of materials. So there have already been numerous attempts to employ polymeric

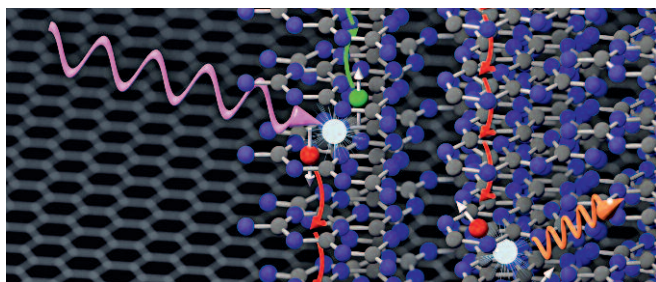

Charge carriers in polymeric carbon nitrides always take paths perpendicular to the sheets, as Merschjann's group has now shown. Light creates an electron-hole pair. The opposite happens when an electron and hole meet under certain conditions (forming a singlet exciton) and emit light (fluorescence). A graphene lattice is shown in the background.

carbon nitrides as cost-effective photocatalysts for solar-powered water splitting. However, the efficiency levels so far have remained comparatively low.

The team headed by Dr. Christoph Merschjann, who works at the HZB Institute of Methods for Material Development and at Freie Universität Berlin, and Prof. Stefan Lochbrunner from the University of Rostock have for the first time precisely probed the processes occurring during light-induced charge separation. The cooperation was initiated by the Cluster Project "Light2Hydrogen". The aim of this project, funded with ten million euros from 2010 to 2014 by the Federal Ministry for Education and Research, was to develop the bases for photocatalysis-based technology for producing hydrogen directly from water using sunlight, as well as the first technical implementation. Another aim

is to incite long-term, cross-regional and international cooperation between various institutions.

"The most interesting result has been that charges are basically only transported along one dimension during this process, perpendicular to the graphite-like layers," explains Merschjann. The light creates an electron-hole pair that subsequently migrates in opposing directions. Using femtosecond spectroscopy and other spectroscopic time-domain methods, the researchers were able to make the first quantitative mobility and lifetime measurements of the charge carriers. This revealed that the charge mobility attains values similar to those in conventional organic semiconductor materials. Moreover, the charge carriers are long-lived before recombining again.

### Interesting applications with graphene

Polymeric carbon nitrides are not only non-toxic and cost-effective, they are also extremely durable because they are chemically very stable and can withstand temperatures of up to about 500°C. Components made of these kinds of compounds could therefore be employed in environments that are unsuitable for today's organic electronics. Merschjann finds the prospect of growing these compounds on ordered substrates, such as graphene for example, especially interesting. This is because graphene possesses extremely high in-plane conductivity, while carbon nitrides primarily conduct perpendicularly to the sheets. "Carbon nitrides need not fear competition with conventional organic semiconductor materials. On the contrary, entirely new kinds of all-organic optoelectronic components might be built using their property of being essentially one-dimensional semiconductors," Merschjann anticipates. He is currently making direct measurements of the charge carriers in a DFG-funded research project at Freie Universität Berlin. arö

Advanced Materials (DOI: 10.1002/adma.201503448): Complementary Graphenes: 1D Interplanar Charge Transport in Polymeric Graphitic Carbon Nitrides; C. Merschjann, S. Tschierlei, T. Tyborski, K. Kailasam, S. Orthmann, D. Hollmann, T. Schedel-Niedrig, A. Thomas and S. Lochbrunner

## HOW NANOPARTICLES IMPROVE THE EFFICIENCY OF SOLAR CELLS

Scientists at HZB have proven for the first time how **titanium dioxide nanoparticles** attached to the back side of ultra-thin CIGSe solar cells influence the efficiency of those solar cells. This could allow them to be produced even thinner and more cheaply.

CIGSe solar cells are made of a thin chalcopyrite layer consisting of copper, indium, gallium and selenium, and can achieve high efficiencies in transforming sunlight into electricity. Since indium is becoming scarce and expensive, it is in everyone's interest to reduce the thickness of the active CIGSe layer, although this also reduces the efficiency quite severely. Scientists at Helmholtz-Zentrum Berlin have produced high-quality, ultrathin CIGSe layers and increased their efficiency by adding an array of tiny nanoparticles between the back contact and the active layer.

Nanoparticles of sizes in the order of a wavelength interact with light in specific ways. A young investigator group at Helmholtz-Zentrum Berlin, led by Professor Martina Schmid, is investigating how to use arrangements of such nanoparticles to improve solar cells and other optoelectronic devices.

### Nanoparticles between different layers of the solar cell

CIGSe solar cells are established thin-film devices with active layers a few micrometres thick. Their thickness, and thus their price, cannot be endlessly reduced because as soon as the active layer becomes thinner than one micrometre, a problem arises: more and more charge carriers meet and recombine at the back contact, becoming "lost" for the purpose of producing electricity.

"It took me more than one year to be able to produce ultrathin layers of only 0.46 micrometres, or 460 nanometres, which still reach reasonable efficiencies up to 11.1 per cent," Guanchao Yin recounts from his PhD project. He

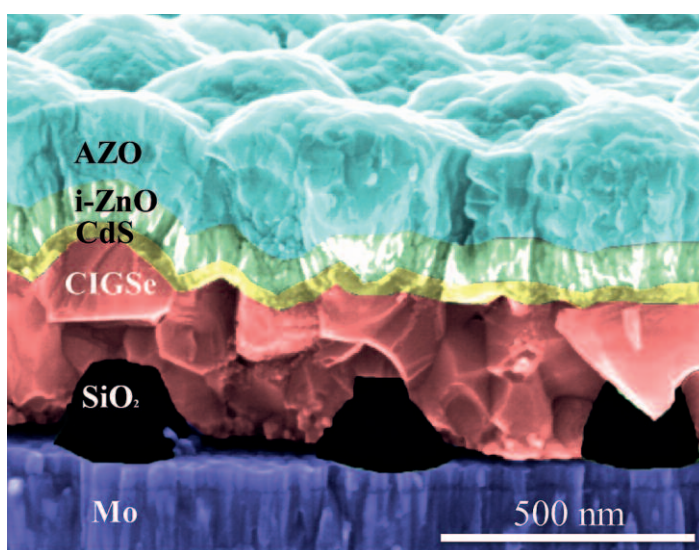

The SiO<sub>2</sub> nanoparticles (black) have been imprinted directly on the molybdenum substrate (purple) which corresponds to the back contact of the solar cell. On top of this structured substrate, the ultrathin CIGSe layer (red) was grown at HZB, and subsequently all other layers and contacts needed for the solar cell. Since all layers are extremely thin, even the top layer exhibits deformations matching the pattern of the nanoparticles.

then started to investigate how to implement nanoparticles between different layers of the solar cell. His supervisor Martina Schmid discussed this with Prof. Albert Polman, one of the pioneers in the field of nanophotonics, at the Center for Nanooptics, Amsterdam, with whom she had already been in contact for some time. They proposed to produce arrays of dielectric nanoparticles using nano-imprinting technologies.

### No big effect from nanoparticles on top

In a first step, the colleagues in Amsterdam implemented a pattern of dielectric titanium dioxide nanoparticles (TiO<sub>2</sub>) on top of Yin's ultrathin solar cells; the idea was that they would act as light traps and increase absorption in the CIGSe layer. But this did not increase the efficiency as much as it had proved to do in Si-based solar cells. Yin then continued testing and ultimately discovered what worked best: a nanoparticle array not on top but on the back contact of the cell.

The colleagues from Amsterdam produced an array of SiO<sub>2</sub> nanoparticles directly on the molybdenum substrate, which corresponds to the back contact of the solar cell. On top of

this structured substrate, Yin grew the ultrathin CIGSe layer, and subsequently all the other layers and contacts needed for the solar cell. With this configuration, the efficiency increased from 11.1 to 12.3 per cent, and the short-circuit current density of the ultrathin CIGSe cells increased by more than two milliamperes per square centimetre. With additional anti-reflective nanoparticles at the front, efficiencies even increased to 13.1 per cent.

#### Nanoparticles prevent charge carrier loss

“This leads to efficient light trapping and does not deteriorate the cell,” Yin explains. Further studies indicate that the nanoarray of dielectric SiO<sub>2</sub> nanoparticles on the back side could also increase efficiency by reducing the chances for charge-carrier recombination. “This work is just a start; we now have new ideas for further designs to enhance absorption and reduce recombination, thus increasing efficiencies by making use of optical and electrical benefits of the nanoparticles,” Martina Schmid says. arö



The performance of CIGSe solar cells can be significantly improved by adding antireflection nanoparticles on the front and back side of the cells. Layer thicknesses can also be further reduced, allowing for cheaper production of solar cells.

ACS Nano, 2015, 9 (10), pp 9603–9613 (DOI: 10.1021/acsnano.5b04091): Light coupling and trapping in ultra-thin Cu(In,Ga)Se<sub>2</sub> solar cells using dielectric scattering patterns; M.-C. van Lare, G. Yin, A. Polman and M. Schmid

## AN ALTERNATIVE TO PLATINUM IN CATALYSTS

Teams at HZB and TU Darmstadt have produced a cost-effective catalyst material for fuel cells using a new preparation process which they analysed in detail. It consists of **iron-nitrogen complexes** embedded in tiny islands of graphene. The results of the research with the catalysts are interesting for solar fuels research as well.

**F**uel cells convert the chemical energy stored in hydrogen into electrical energy by electrochemically “combusting” hydrogen gas with oxygen from the air into water, thereby generating electricity. As a result, future electric automobiles might be operated quite well with fuel cells instead of with heavy batteries. But for the “cold” combustion of hydrogen and oxygen to function well, the anode and cathode of the fuel cell must be coated with extremely active catalysts. The problem is that the platinum-based catalysts employed for this contribute about 25 per cent of the total fuel-cell costs. However, iron-nitrogen complexes in graphene (known as Fe-N-C catalysts) have been achieving levels of activity

comparable to Pt/C catalysts for several years already. “Systematic investigation of Fe-N-C catalysts was difficult though, since most approaches for preparing the materials lead to heterogeneous compounds. These contain various species of iron compounds such as iron carbides or nitrides besides the intended FeN<sub>4</sub> centres”, explains Sebastian Fiechter of HZB.

#### Purification process removes interfering compounds

“We had already developed a new preparation method at HZB a few years ago to produce an inexpensive catalyst material from organometallic compounds such as iron or cobalt porphyrin”, reports Peter Bogdanoff, HZB. Ulrike

Kramm and Iris Herrmann-Geppert improved the process for producing it as part of their doctoral studies at HZB. As a result, the metal-N-C catalysts developed at HZB held the world record for the highest density of catalytically active centres of various nitro-metallic compounds up to about 2011. However, it remained unclear as to which inorganic compounds influenced the catalytic efficiency. The team was now able to determine this.

The highlight in the current work is a purification process (a combination of thermal treatment with a subsequent etching step) by which the proportion of metallic compounds that interferes with catalytic activity can be substantially reduced, even for catalysts that are highly heterogeneous. The interesting thing here is that the activity increases enormously! Ulrike Kramm, who has since become a junior professor at TU Darmstadt, was successful in purifying several catalysts to such an extent that all the iron present in the graphene layers was exclusively in the form of complexes made of iron and four nitrogen atoms ( $\text{FeN}_4$ ). The scientists thereby disproved the hypothesis debated among experts by which improvement in the activity of the  $\text{FeN}_4$  centres only resulted from promoters, as they are known, such as iron nanoparticles.

#### $\text{FeN}_4$ centres provide the high catalytic efficiency

“To check this hypothesis, we employed numerous complex measurement techniques such as Mößbauer spectroscopy, electron paramagnetic resonance spectroscopy and X-ray absorption spectroscopy at BESSY II. These enabled us to

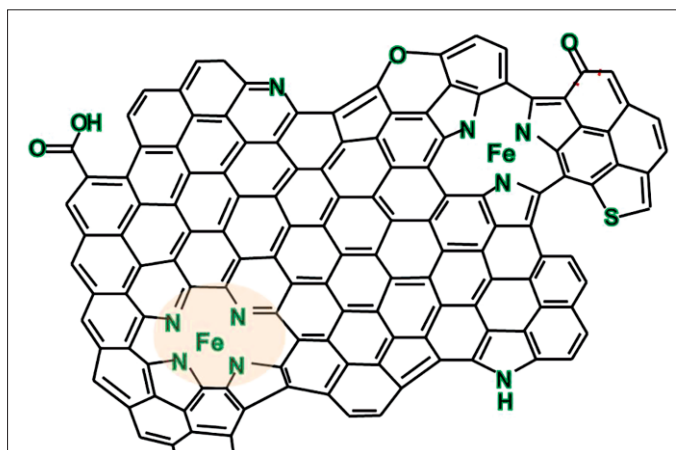

Nano-island of graphene in which iron-nitrogen complexes are embedded. The  $\text{FeN}_4$  complexes (shown in orange) are catalytically active.

precisely survey the atomic structure of the catalytic centres”, Kramm reports. “The purification process enables us now to create catalysts having exclusively  $\text{FeN}_4$  centres. This allows us to subsequently select compounds to be added afterwards as promoters that further improve the activity level or stability of these catalysts”, Kramm summarises her research approach at TU Darmstadt. Sebastian Fiechter and Peter Bogdanoff are continuing their research at HZB on novel catalysts, especially in regard to hydrogen generation using sunlight. “We can also use the insights into how these metal-N-C catalysts work in our ongoing development of catalysing materials for solar-based hydrogen production at HZB,” says Fiechter. To-

gether, the research activities at HZB and TU Darmstadt could enable the development of a complete regenerative energy cycle using solar hydrogen in low-cost fuel cells, thus producing electricity without climate gas emission.

arö



Vehicles with fuel cells such as the Toyota Mirai, which is fuelled with hydrogen, need highly active catalysts for the “cold” combustion of hydrogen and oxygen from air. So far, very expensive platinum catalysts are used. Thanks to research done at HZB and TU Darmstadt, less precious materials could one day be used to make much cheaper catalysts that work at similar efficiencies.

Metal-Nitrogen doped carbon with exclusive presence of  $\text{MeN}_4$ -type sites active for the ORR; U. I. Kramm, I. Herrmann-Geppert, J. Behrends, K. Lips, S. Fiechter and P. Bogdanoff

J. Am. Chem. Soc., 2016, 138 (2), pp 635–640 (DOI: 10.1021/jacs.5b11015):

On an easy way to prepare

## MIXED CRYSTALS IN THE CRYSTAL

The Molecular Systems Joint Research Team of Helmholtz-Zentrum Berlin and Humboldt-Universität zu Berlin have analysed at BESSY II how doping **molecules integrate into the chemical structure of organic semiconductors**. The fact that it differs from how they integrate into inorganic semiconductors presents new tasks for research.

Current semiconductor technology is based on silicon, an inorganic semiconductor material into which impurity atoms are introduced – or “doped” – to increase conductivity and tailor the electronic structure for use in electronic components. However, organic solid-state materials made of conjugated molecules or polymers also exhibit promising semiconducting properties, making their application feasible in organic electronics. The enormous application potential of organic electronics has been clearly demonstrated by the success of organic LEDs (OLEDs) in recent years. Oligothiophene (4T) and polythiophene (P3HT), two typical organic semiconductors, can be doped with a second type of molecule – such as a strong electron acceptor (F4TCNQ) – to control electrical conductivity. Until recently, however, exactly how these guest molecules integrate into the host structure has been poorly understood. A homogeneous distribution analogous to that in inorganic semiconductors had therefore always been assumed.

### Co-crystallites as dopants

An international group headed by the Molecular Systems Joint Research Team at HZB and Humboldt-Universität zu Berlin has now been able to demonstrate that this is not the case for either oligothiophene or polythiophene. The group, co-led by Dr. Ingo Salzmänn and Prof. Norbert Koch, had previously experimented with and already modelled other systems to learn how doping organic semiconductors affects their electronic structure and thus their conductivity. This produced evidence of unusual characteristics of this class of materials in which hybridisation of the molecular orbitals plays a key role. They therefore fabricated a series of organic thin films with increasingly heavy levels of doping and investigated these samples using X-ray diffraction techniques at the KMC-2 beamline at BESSY II, managed by Dr. Daniel Töbrens. They were able to precisely determine the dependence of the crystalline structure on the degree of doping using this technique.

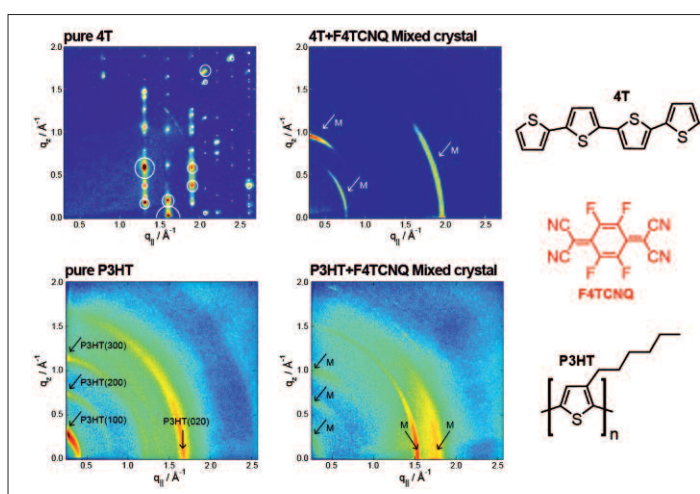

Left, X-ray scattering reveals characteristic reflections of the pristine host lattices for 4T (top) and P3HT (bottom). In the case of heavily doped materials (right column), fundamentally different reflections occur that provide evidence for the presence of co-crystallites formed by the dopant and host.

Their results for the organic semiconductors 4T and P3HT showed that the guest molecules – contrary to expectations – are not uniformly incorporated into the host lattice at all. Instead, a second crystalline phase of host/guest co-crystallites is formed in the pure crystalline host matrix. These co-crystals function in the role of dopant in place of the actual, pure doping molecules in such systems. “It is important to understand the fundamental processes involved in the molecular electrical doping of organic semiconductors more precisely,” explains Salzmänn. “If we want to successfully employ these kinds of materials in applications, we need to be able to control their electronic properties just as precisely as we customarily do today with inorganic semiconductors.”

arö

Nature Communications, 6: 8560 (DOI: 10.1038/ncomms9560): Charge-transfer crystallites as molecular electrical dopants; H. Méndez, G. Heimel, S. Winkler, J. Frisch, A. Opitz, K. Sauer, B. Wegner, M. Oehzelt, C. Röthel, S. Duhm, D. Töbrens, N. Koch and I. Salzmänn



## DEPLETION AND ENRICHMENT OF CHLORINE

X-ray spectroscopy at BESSY II reveals the inhomogeneous distribution of chlorine in a special class of perovskite materials. The discovery could help to **enhance the efficiencies of perovskite thin-film solar cells** by controlled processing to optimise the chlorine distribution.

After performance breakthroughs in 2012, a new class of organic-inorganic absorber material for solar cells has raised worldwide attention. These organometallic halide perovskites are low in cost, easy to process, and have enormous potential for efficient solar energy conversion: power conversion efficiencies up to 20.1 per cent have already been reported. Pioneering work has been led by the group of Henry Snaith at the University of Oxford in the UK. Optimal performance for these devices has been achieved with methylammonium lead halide absorbers which use a

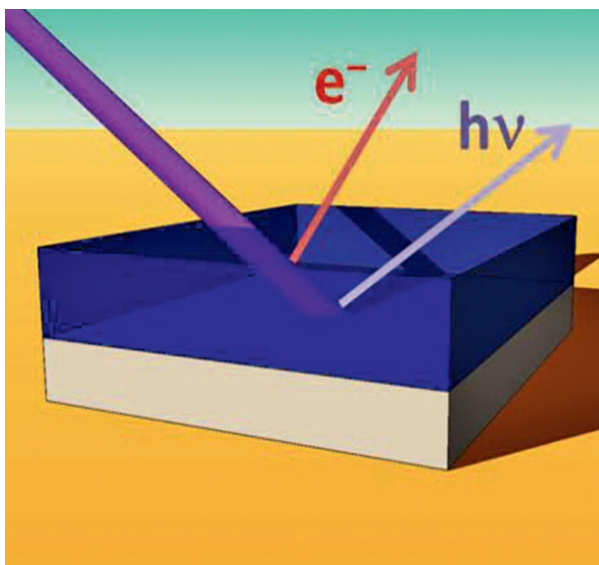

X-ray spectroscopies have shown a higher chlorine concentration near the perovskite/TiO<sub>2</sub> interface than throughout the rest of the perovskite film.

mixture of chlorine and iodine. Despite typical chlorine-to-iodine concentration ratios of 0.66 in the initial precursor solution, the perovskite films contain little or no chlorine. Depending on the processing procedures, chlorine tends to be depleted, whereas the iodine atoms remain in the material. Nevertheless, the chlorine seems to benefit the efficiency of the absorber material, but it is still not understood how and why.

### Analysing chlorine in deeper layers

A team of HZB scientists has now analysed samples from the Snaith group and unveiled how chlorine is distributed in the perovskite absorber layer. They used X-ray spectroscopies at the BESSY-II facility to probe the distribution of chlorine in a mixed halide, organic-inorganic perovskite absorber layer. With hard X-ray photoelectron spectroscopy (HAXPES) experiments at the KMC-1 beamline, they probed the surface of perovskite layers and found almost no chlorine near the surface. With a different method, fluorescence yield X-ray absorption spectroscopy (FY-XAS), they probed more deeply into the layers of the sample. “We have observed a higher concentration of chlorine near the perovskite/TiO<sub>2</sub> interface than in the rest of the thin film”, David Starr, first author of the publication, explains.

### Chlorine boosts efficiency

Chlorine may potentially play a role in mitigating the effects of vacancies which favour recombination and charge carrier loss, or providing a better template on which to grow the perovskite film. “These results may help to understand the apparent beneficial effects of chlorine for perovskite solar cell device performance and could potentially provide a route to device optimisation,” Marcus Bär, who heads the HZB team, says. “The ultimate goal is to use this knowledge to tailor deposition processes and material compositions to achieve specific desirable properties; perhaps by completely understanding the beneficial role of chlorine in the lead-based perovskite material, we can overcome some of the difficulties involved in replacing the lead with a less toxic material.”

arö

Energy Environ. Sci., 2015, 8, 1609 (DOI: 10.1039/c5ee00403a): Direct observation of an inhomogeneous chlorine distribution in CH<sub>3</sub>NH<sub>3</sub>PbI<sub>3-x</sub>Cl<sub>x</sub> layers: surface depletion and interface enrichment; D. E. Starr, G. Sadoughi, E. Handick, R. G. Wilks, J. H. Alsmeier, L. Köhler, M. Gorgoi, H. J. Snaith and M. Bär

## NANOPARTICLES MAKE FOR BETTER SOLAR CELLS

HZB chemists have developed a method called “**spray pyrolysis**” for applying precious metal nanoparticles onto solar cells. It will help materials researchers to build solar cells that are more efficient at converting solar energy into electricity.

**S**o often in science, behind a great breakthrough is an incredibly simple idea. Materials researchers have long known, for example, that a solar cell only converts a fraction of the incoming sunlight into electric current. A lot of light simply escapes from the cell again, unused. “If you redirect as much as possible of this otherwise lost radiation back into the absorber, then at least some of it can still be converted into electricity,” explains Martha Lux-Steiner, who until March 2016 headed the HZB Institute for Heterogeneous Material Systems. An excellent way to achieve this is to add an ultra-thin layer of silver nanoparticles, for example. The question then is: what is the simplest and cheapest way to apply this ultra-thin layer

of silver nanoparticles? One answer is spray pyrolysis, a method developed by Prof. Dr. Christian-Herbert Fischer, head of the “Wet Chemistry” work group, and Dr. Yanpeng Fu from the junior research group NanooptiX (Nanooptical Concepts for Photovoltaics) that deposits tiny nanoparticles of the precious metals gold, silver and copper onto a surface. To apply gold, for example, the researchers start with tetrachloroauric acid, which is used among other things in the process of gold plating and is thus available affordably from specialist suppliers. This acid is dissolved in ethanol – an equally low-priced alcohol. The researchers atomise the solution using the same type of ultrasound device found in run-of-the-mill air humidifiers. This produces minute droplets that are small enough to float in the air as a so-called aerosol.

### Spray-depositing ultra-thin layers

“We guide this aerosol onto a surface that is about 200 degrees Celsius hot,” Fischer explains the next step. At this temperature, the alcohol quickly evaporates, and the tetrachloroauric acid stays behind. Being a precious metal, the gold is bound relatively loosely in this form. Even temperatures that are quite moderate for such chemical reactions of say 200 degrees Celsius are therefore enough to break the compound down into its constituents. This produces chlorine gas, which is extracted off, and gold, which precipitates as a metal onto the hot surface. Only few atoms remain adhered to it at first. But these seeds then draw in other atoms, and grow into tiny crystals whose edges are only about ten to 65 nanometres, or 0.01 to 0.065 thousandths of a millimetre long.

Chemists call this sort of reaction, where high temperatures alone break down relatively large compounds into their constituents, “pyrolysis” after the Greek words for “fire” (pyr) and “splitting” (lysis). Because the tetrachloroauric acid is sprayed on, the method is called “spray pyrolysis”. The method works very similarly with compounds of other precious metals such as silver and copper. “So, we are currently working very intensively on producing silver nanoparticles for improving solar cells,” reports

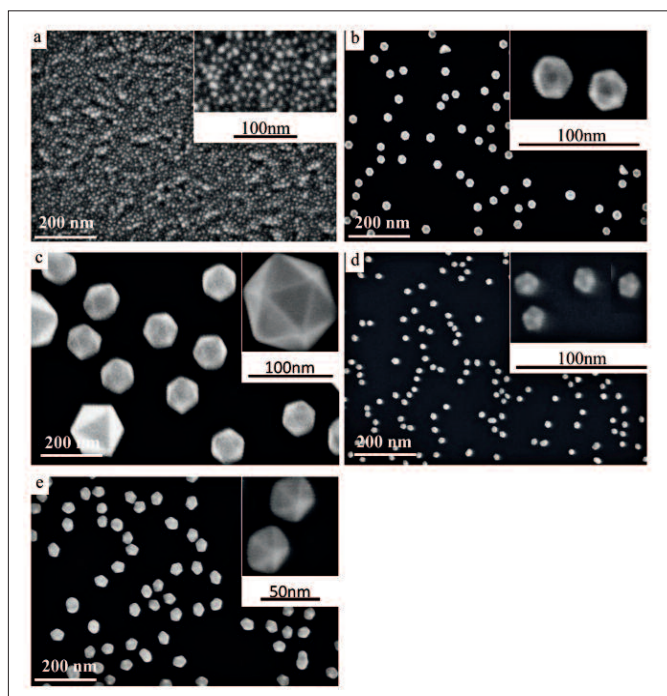

SEM images of gold quasi-spheres grown on molybdenum (a), icosahedra grown on silicon with edge length of 15 and 65 nanometres (b and c), decahedra grown on silicon with edge length of 10 and 20 nanometres, respectively (d and e). The insets show the corresponding close-up views.

Martha Lux-Steiner who, now a professor emerita, is happy to share a decade of experience in this field with her colleagues.

#### The greater the surface area, the better the reaction

While conducting his experiments, Fischer's attention was drawn to the work of colleagues in other HZB groups, who were also studying gold nanoparticles as catalysts for chemical reactions. They can now rely on Fischer's solution to optimise their compounds, since they share the same goal of coating a surface with the thinnest possible layer of minute catalysts where the desired reaction can take place rapidly and cheaply. Hydrogen, for example, which is needed for many reactions and can power fuel cells and combustion engines, can be obtained from carbon monoxide and water with the help of a gold catalyst. A gold bar is of little use here, since the reactions only take place on the outer surface of the precious metal. The surface of a lump of gold offers too little space for all the molecules to achieve a worthwhile yield.

Exploiting a simple relationship solves this problem: if you break the gold bar down into many tiny pieces, then the overall surface area increases enormously, and the reactions really pick up speed. And the relationship continues to be true the smaller the particles become. Which means gold nanoparticles would be ideal. The trouble is, when distributed in a liquid, the particles tend to clump together, meaning their surface area quickly shrinks again. To prevent clumping, the researchers add organic molecules that adhere to the surface of the nanoparticles. Unfortunately, in adhering to the particles, these "stabilisers" themselves worsen the catalytic action to a certain extent, since they block some of the valuable outer surface – in technical jargon, they "poison the surface". And, of course, there are still further problems that tarnish the success of gold nanoparticle catalysts. Spray pyrolysis, however, could once again come to the rescue in these applications. The gold nanocrystals namely grow on solid materials without the help of stabilisers, and so without the need to poison the surface. "These naked gold nanoparticles catalyse far better than those with stabilisers," Fischer explains. This can be proven in a trivial experiment with a frequently used test reaction, where the catalyst converts nitrophenol into aminophenol. If the researcher dips the nanoparticles into a solution of stabilisers before the experiment, then they poison the surface just as they would with conventional catalysts. But, if the HZB chemists leave out this dipping step, then the test reaction runs up to four times more efficiently than with a poisoned catalyst.

#### Control of nanoparticle size in a targeted manner

It seems, therefore, that spray pyrolysis is a promising way to significantly improve not only the efficiency of solar cells

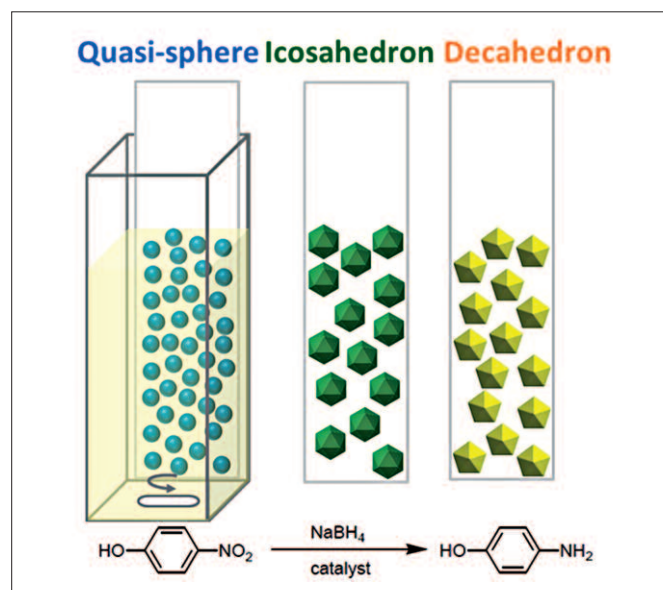

Schematic illustration of the self-assembled gold nanoparticles, that is, quasi-spheres, icosahedra, decahedra, on the substrate used as heterogeneous catalysts for the reduction of 4-NP.

but also the effectiveness of gold nanoparticle catalysis. "The material can be well optimised, to boot," Fischer continues. For example, the researcher can very easily control the size of the nanoparticles and thus the surface area of the catalyst: the longer he sprays the tetrachloroauric acid solution onto the alcohol solution, the larger the crystals become. Different concentrations of this gold compound yield different crystal shapes. The type of surface onto which Fischer sprays the aerosol also strongly influences the shape of the growing crystals. If the researchers add copper ions to the spray solution, then they get even more crystal shapes.

Accordingly, the scientists need only adjust the conditions and the nanoparticles organise themselves into targeted shapes. The method is also inexpensive. Not only because it is intrinsically simple – and renders, for example, the otherwise commonly used and expensive masking technique obsolete – but also because the gold nanoparticles can be reused, keeping the material costs down. One whole square metre of catalyst surface barely contains 36 milligrams of gold, at a market value of 1.20 euros. Spray pyrolysis is thus a low-cost method by which even large surfaces can be treated affordably.

*rk*

Advanced Synthesis & Catalysis, 2015 (DOI: 10.1002/adsc.201500848): In-situ Synthesis of Stabilizer-Free Gold Nanocrystals with Controllable Shape on Substrates as Highly Active Catalysts for Multiple Use; Y. Fu, Y. Lu, F. Polzer, M. Ch. Lux-Steiner and C.H. Fischer

## NEW LAB FOR THE RESEARCH OF ENERGY MATERIALS

To conduct cutting-edge research on novel energy materials with the **most advanced ZEISS electron microscopes** available – that is the mission of the partnership between HZB and ZEISS. The laboratories that were built for this cooperation were officially opened at the end of 2015.

Outstanding knowledge and experience in implementing advanced microscopy technologies and applications are important elements for the set-up of the ZEISS labs@location programme. HZB's reputation for excellence in industry and science led to its being invited to join ZEISS in the expansion of this scientific network. Prof. Anke Kaysser-Pyzalla, scientific director of HZB, outlined the benefits for HZB: "This collaboration fits perfectly with HZB's strategy of setting up core labs for our research on energy materials using state-of-the-art and sometimes even unique equipment. The core labs complement and enhance our scientific capabilities, focussed on several areas of energy research. In addition, they will be attractive infrastructures available also to external users, and will stimulate further strategic partnerships."

Dr. Markus Weber, head of the ZEISS Microscopy division, spoke during the dedication of ZEISS labs@location at HZB about the importance of the scientific community for ZEISS. "Our intention is to bring together the world's leading scientists and researchers – so that they learn from one another, exchange scientific knowledge, and mutually inspire one another to new achievements."

### Cooperation suits the HZB strategy

HZB is equipped with the newest scanning electron microscopes (SEMs) and ion microscopy systems at its Lise-Meitner-Campus in Berlin-Wannsee. The ZEISS Cross-beam 340 focussed ion beam (FIB) SEM, ZEISS MERLIN field emission (FE) SEM, and ZEISS ORION NanoFab ensure that the scientists can prepare and image materials at nanoscales using the most advanced technology. The researchers have already successfully demonstrated that



Prof. Dr. Anke Kaysser-Pyzalla (5th from left), scientific director of HZB, Thomas Frederking (6th from left), commercial director of HZB, Dr. Markus Weber (left), and guests from politics and science at the inauguration of the laboratory established as part of the ZEISS labs@location programme.

a nano-scale modification to the silicon surface of a thin-film solar cell increases its light absorption by two-thirds. This allowed the efficiency of the solar cell to be raised considerably.

### Workshops and scientific exchange

The cooperation of ZEISS and HZB includes joint workshops and training programmes as well as demonstrations of the equipment and scientific exchanges. Scientific collaborations can count on joint consulting from experts at HZB and specialists from ZEISS for specific applications and system configurations. Research partners will obtain additional perspectives on their research from this close cooperation, while HZB and ZEISS research and development efforts stand to benefit as well.

## WHISPERING GALLERY MODES FOR THE LIGHT

Scientists at the HZB and the Max-Planck-Institute for the Science of Light have revealed that nanostructures intensify the **luminescence of silicon, a semiconducting material**. New applications are conceivable, including silicon-based nanolasers.

**S**ilicon is a conventional material for computer chips and solar cells. However, even though the properties of silicon are well known, nanostructures still offer surprises. A team at the HZB Institute of Nanoarchitectures for Energy Conversion together with the Max Planck Institute for the Science of Light (MPL) have shown for the first time how light behaves in a silicon nanocone. The numerical simulations and experiments now demonstrate why this tapered geometry is able to emit optically excited luminescence a great deal better than comparably sized nanocolumns. “The cones function like arrays of tiny whispering galleries – not for sound, but rather for light”, explains Sebastian Schmitt, first author.

### Strong luminescence in nanocones

Schmitt and his colleague George Sarau irradiated individual silicon nanocolumns and nanocones using red laser light (660 nanometres) and measured the radiation that was subsequently emitted as luminescence by the sample. It is known that luminescence in silicon (without any nanostructuring) is normally very low because excited electrons hardly recombine radiatively in this material (indirect band gap). In contrast, the nanostructures convert a much greater portion of the incident light into electromagnetic radiation in the near-infrared region. This effect in nanocones is 200 times stronger than in nanocolumns. “This is the highest luminescence gain ever measured in a silicon structure”, says Schmitt. The team can also explain this effect. The propagation of electromagnetic waves in various geometries of silicon nanowires can be calculated using numerical modelling. Because the diameter of the nanocone changes with height, there are several levels at which the infrared light is constructively superposed to form standing waves.

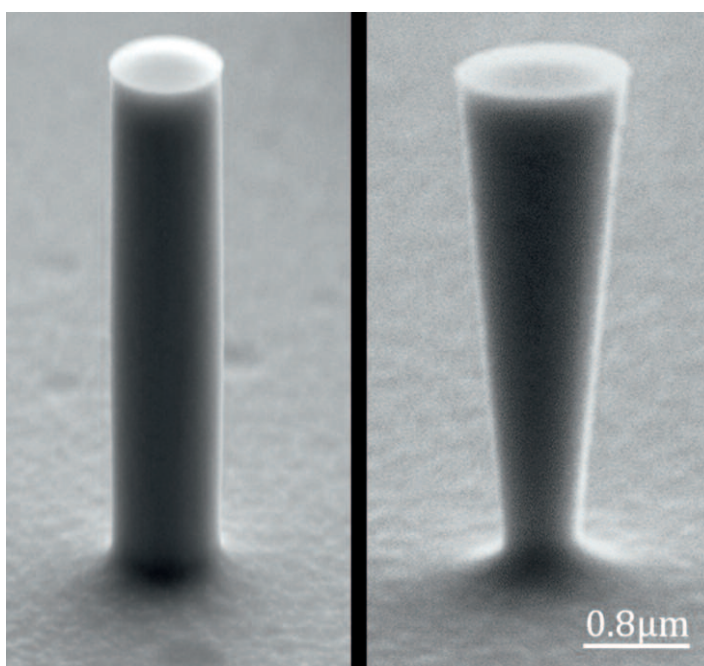

Nanostructures of silicon shown in scanning electron microscope image. The diameter of the nanocolumns is 570 nm. By comparison, the nanocones taper from their upper diameter of 940 nm down to 360 nm at their base.

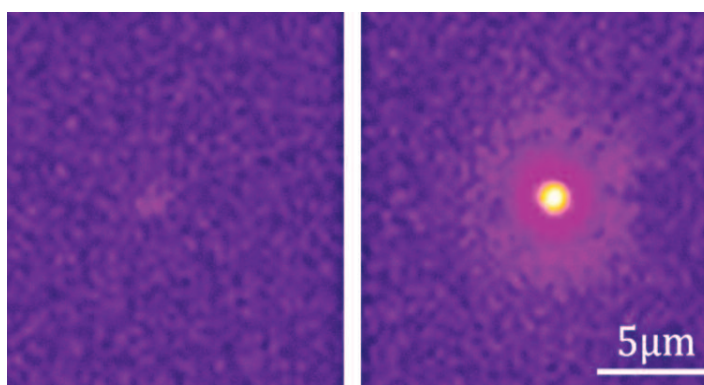

An infrared camera captures the luminescence (emission of light) after optical excitation of both nanostructures.

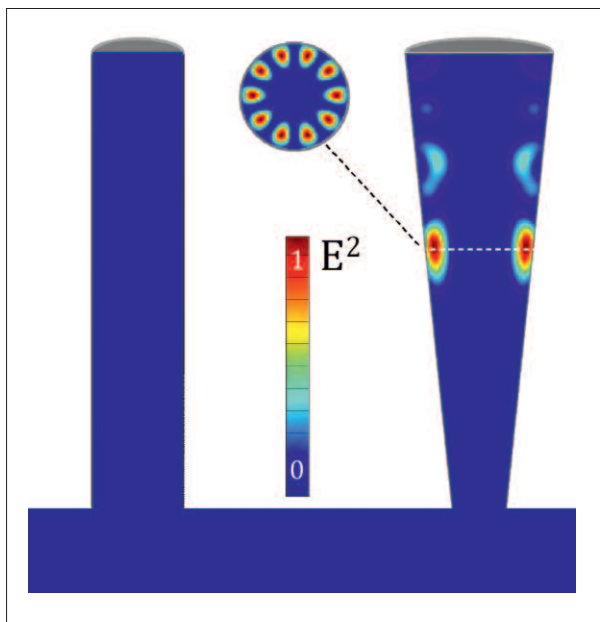

The energy density of the light (1027 nm) in cross-sections of the nanostructures can be numerically modelled. Whispering gallery modes only arise in nanocones. The luminescence is amplified 200 times more in nanocones than in nanocolumns.

This amplification facilitates the increased excitation of electrons and thus the release of luminescence. This phenomenon is known as the Purcell Effect in the field. If a light source is located in an optical resonator, the spontaneous emission of light increases. The nanocones act as outstanding resonators, like optical whisper galleries for light.

#### Design rules for novel devices

“These types of nanostructures made of individual cones are not difficult to fabricate”, explains Schmitt. They would be easily integrated as new components into predominant CMOS semiconductor fabrication techniques used for diodes, optoelectronic switches, and optical sensors, for example. These structures could even produce laser light in conjunction with a suitable optically active medium, physicists surmise. They can derive simple design rules for semiconductor nanostructures with this kind of knowledge to exert control over the number and wavelengths of hosted modes and thereby control the luminescence”.

*arö*

Scientific Reports 5, 17089 (2015) (DOI: 10.1038/srep17089): Observation of strongly enhanced photoluminescence from inverted cone-shaped silicon nanostructures; S. W. Schmitt, G. Sarau and S. Christiansen

## TANDEM SOLAR CELL ACHIEVES RECORD EFFICIENCY

Teams from HZB and École Polytechnique Fédérale de Lausanne have successfully combined a silicon heterojunction solar cell with a perovskite solar cell monolithically into a tandem device. The **hybrid tandem cell** showed an efficiency of 18 per cent and there are even prospects for as much as 30 per cent.

**O**rganic-inorganic perovskite materials are one of the biggest surprises in solar cell research. In just six years, the efficiency of perovskite solar cells has increased five-fold; moreover, perovskite solar cells can be manufactured from solution and be cost-effectively printed on large areas in the future. Because perovskite layers absorb light in the blue region of the spectrum very efficiently, it is useful to combine these with silicon layers that primarily convert long-wavelength red and near-infrared light. Nevertheless, the construction of these kinds of tandem cells in a monolithic stack of deposited layers has been difficult. This is because for high-efficiency

perovskite cells, it is usually required to coat the perovskite onto titanium dioxide layers that must be previously sintered at about 500 degrees Celsius. However, at such high temperatures, the amorphous silicon layers that cover the crystalline silicon wafer in silicon heterojunction degrades.

#### New functional layers

A team headed by Prof. Bernd Rech and Dr. Lars Korte at the HZB Institute for Silicon Photovoltaics in cooperation with HZB's PVcomB and a group headed by Prof. Michael Graetzel at the École Polytechnique Fédérale de Lausanne (EPFL) are the first to have fabricated this kind of mono-

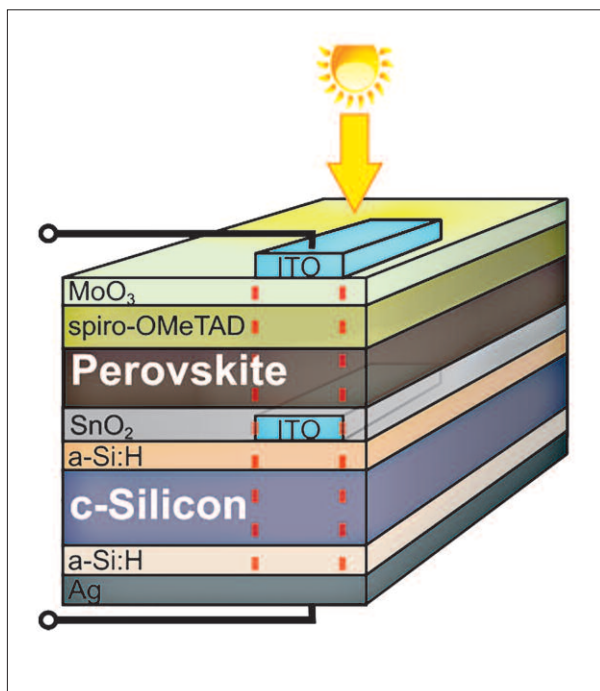

Schematic structure of the silicon-perovskite hybrid tandem cell.



A cross section through the tandem cell is shown by this SEM-image. A heterojunction silicon cell provides the base. A very thin layer of transparent tin dioxide was deposited on this bottom cell, followed by 500 nm of perovskite as well as 200 nm of spiro-OMeTAD hole-conductor material. Thin MO<sub>3</sub> serves as a protective layer between this hole conductor and the transparent top electrode of ITO.

lithic tandem cell. They were successful in depositing a layer of tin dioxide at low temperatures to replace the usually used titanium dioxide. A thin layer of perovskite could then be spin-coated onto this intermediate layer and covered with hole-conductor material. In addition, a crucial element in the device architecture is the transparent top contact. Typically, metal oxides are deposited by sputtering, but this would destroy the sensitive perovskite layer as well as the hole-conductor material. Therefore, the team from HZB modified the fabrication process and incorporated a transparent protective layer.

### High efficiency and high open-circuit voltage

At 18 per cent, this tandem cell attained an efficiency level that is nearly 20 per cent higher than the efficiency of individual cells. The open-circuit voltage is 1.78 volts. “At that voltage level, this combination of materials could even be used for the generation of hydrogen from sunlight”, says Dr. Steve Albrecht, lead author and postdoc in the group of Bernd Rech. He developed the device design of the tandem cell and is coordinating the collaboration with EPFL. “The 18 per cent efficiency we measured is certainly very good, but light is still being lost at the surface in the present architecture”, he explains and is planning further improvements.

A textured foil on the front side might be able to catch this light and couple it into the cell, which would further increase the cell’s efficiency. The heterojunction silicon solar cell that simultaneously functions as the bottom cell and the substrate for the perovskite top cell offers further potential for improvement. “This perovskite-silicon tandem cell is presently still being fabricated on a polished silicon wafer. By texturing this wafer with light-trapping features such as random pyramids, the efficiency might be increased further to 25 or even 30 per cent”, says Dr. Lars

Korte, head of the silicon heterojunction solar cell group at the Institute for Silicon Photovoltaics.

### Integration into existing technologies

But almost more important than the maximum efficiency is the integration into existing technologies. “Silicon technology currently dominates 90 per cent of the market, which means there are many established production facilities for silicon cells”, says Prof. Bernd Rech. “The perovskite layers could considerably increase the efficiency level. To achieve this, the fabrication techniques only need to be supplemented with a few more production steps. For that reason, our work is also extremely interesting for industry. However, the problems

of long-term stability and the lead content of perovskite solar cells still need to be solved in future research.”

*rk*

Energy Environ. Sci., 2016,9, 81-88 (DOI: 10.1039/C5EE02965A): Monolithic Perovskite/Silicon-Heterojunction Tandem Solar Cells Processed at Low Temperature; S. Albrecht, M. Saliba, J. P. Correa Baena, F. Lang, L. Kegelmann, M. Mews, L. Steier, A. Abate, J. Rappich, L. Korte, R. Schlatmann, M. K. Nazeeruddin, A. Hagfeldt, M. Grätzel and B. Rech

## INDUSTRIAL PARTNERS – ANALYSING SOLAR MODULES

Window manufacturer VELUX makes **roof windows featuring an integrated solar module** for powering an electric blind. The Danish company puts PVcomB's long-standing experience in module research and development to good use in its quality control processes.

**A**t the Competence Centre Thin-Film and Nanotechnology for Photovoltaics Berlin (PVcomB), thin-film photovoltaic technologies and products are being developed in collaboration with industrial partners. Co-operative projects with international companies promote technology and knowledge transfer and thus the industrial use of solar energy. One partner is window manufacturer VELUX. The Danish company sells a high volume of roof windows featuring integrated energy-autonomous, solar-powered shade systems. The technology needs no power cables, and can even be retrofitted into existing windows with relative ease.



This VELUX roof window features an energy-autonomous shade system, powered by an integrated photovoltaic component quality-controlled at HZB.

### Phase 1: Quality control

In 2014, VELUX contracted PVcomB to support their quality control procedure and make improvements to their products' PV components. PVcomB has highly modern equipment and years of competence to draw on in analysing thin-film materials, solar cells and modules. The main test method is electroluminescence spectroscopy. In this highly sensitive method, the tested PV module is stimulated with an electric current to emit light. Combining microscopic analyses with this method, scientists led by Dr. Björn Rau were able to reveal bad contacts or material defects such as short circuits in the semiconductors and insulators. Finally, the results of the tests were analysed and assessed for VELUX.



PVcomB has ultra-modern systems for the analysis of solar modules.

### Phase 2: Evaluation of alternative suppliers

A second phase of the cooperative project is concerned with finding alternative module manufacturers. For this characterisation job, the engineers at PVcomB developed a system that can distinguish good solar modules from faulty ones before they are installed. Performance is tested by luminescence measurement and by lock-in thermography. This is where a solar module is placed into specific operating states by an electric potential or even targeted lighting. So-called hotspots can be detected using a high-resolution infrared camera. Very hot individual points indicate a short circuit that will eventually cause problems when the module is used.

“Because we have already been developing and even producing solar modules for many years at PVcomB, we can determine very well which errors are caused by which faults,” Dr. Björn Rau summarises. “Given our long-standing experience with the production technology on the one hand and our skilled analytical methods on the other, we are the ideal partner for such cooperative projects with industry.”

tm



## SOLAR MODULES HIDDEN IN DISPLAY SCREENS

**Semi-transparent solar modules** made by Sunpartner Technologies may one day power mobile devices. They are invisible and can be used in any product featuring glass. The technology is still in its infancy, but PVcomB is helping to bring it to market maturity.

Scientists have been working on quasi-transparent solar modules for a long time. They could convert the windows of buildings and cars, or any other glass surfaces for that matter, into energy generators. So far, the energy yield has been too low for marketable applications, but this could soon change because the technology has almost reached market maturity. French company Sunpartner Technologies has developed a technology for integrating a thin solar cell into glass, such as between the touch-sensitive screen and LCD screen of a telephone, without obscuring the display image. This innovation goes by the brand name “Wysips” – an acronym for “What You See Is a Photovoltaic Surface”. “So you get a display image of full brightness – and yet the same surface acts as a PV module,” Dr. Bernd Stannowski of PVcomB describes the principle. “This component could convert every transparent surface into an energy-generating substrate. Smart windows would have an autonomous energy supply,” he explains. “They could be used, say, in aeroplanes, so that passengers no longer have to pull down a blind, but can simply control the shade with a button instead.”

### Technology cooperation with the market in mind

PVcomB is the developmental partner of Sunpartner Technologies. “Through this cooperation, the company can draw on our extensive competence in the field of processing and analysing thin films and solar cells,” explains



Quasi-transparent solar modules are a highly important development especially for the manufacturers of mobile devices such as smart phones, tablets and smart watches. With them, users could go for days without needing a power outlet to charge their mobile devices.

Stannowski, who heads the project at PVcomB. The task is to continue increasing the efficiency, quality and even production speed in order to optimise the technology for use in the consumer electronics and smart windows markets. The Berlin engineers and scientists are currently experimenting with silicon and CIGSe solar cells. In this project, PVcomB acts not only as a process developer, but also as a partner for manufacturing PV modules in small batches in Berlin, to be processed downstream in a photolithography pilot line in France. “It is important above all to achieve consistently high quality here. PVcomB is a reliable partner for that,” explains Dr. Björn Rau, technology head at PVcomB.

tm

## EFFICIENCY RECORD FOR ARTIFICIAL PHOTOSYNTHESIS

With participation of the HZB, an international team has succeeded in considerably increasing the efficiency for **direct solar water splitting** for the first time since 17 years. The researchers were using a tandem solar cell whose surfaces had been selectively modified.

Solar energy is abundantly available, but unfortunately not constantly and not everywhere. One especially interesting solution for storing this energy is artificial photosynthesis. This is what every leaf can do, namely convert sunlight to “chemical energy”. That can take place with artificial systems based on semiconductors as well. These use the electrical power that sunlight creates in individual semiconductor components to split water into oxygen and hydrogen. Hydrogen possesses a very high energy density, can be employed in many ways and could replace fossil fuels. Until now, the manufacture of solar hydrogen at the industrial

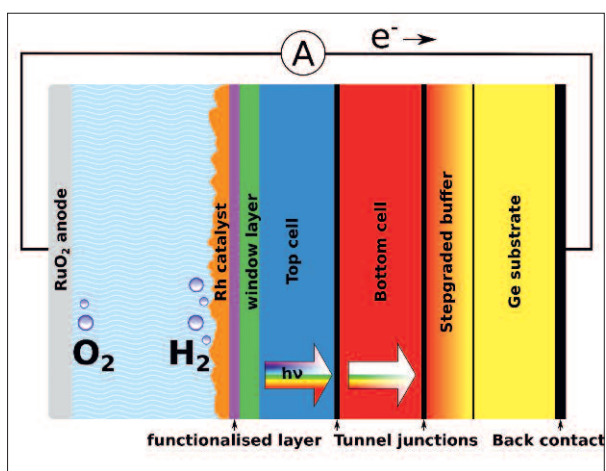

This cell is able to convert 14 per cent of the incoming solar energy into hydrogen.

level has failed due to the costs, however. This is because the efficiency of artificial photosynthesis, i.e. the energy content of the hydrogen compared to that of sunlight, has been too low to produce hydrogen from the sun economically. Scientific facilities worldwide have therefore been researching for many years how to break the record for artificial photosynthesis of 12.4 per cent, which has been held for 17 years by the National Renewable Energy Laboratory (NREL) in the USA. The team from TU Ilmenau, HZB, the California Institute of Technology as well as the Fraunhofer Institute for Solar Energy Systems has considerably exceeded this record

value. Lead author Matthias May, active at TU Ilmenau and the HZB Institute for Solar Fuels, processed and surveyed about one hundred samples in his doctoral dissertation to achieve this. The fundamental components are tandem solar cells of what are known as III-V semiconductors. Using a now patented photo-electrochemical process, May was able to modify certain surfaces of these semiconductor systems in such a way that they functioned better in water splitting.

### Stability improved

“We have electronically and chemically passivated *in situ* the aluminium-indium-phosphide layers in particular and thereby efficiently coupled to the catalyst layer for hydrogen generation. In this way, we were able to control the composition of the surface at sub-nanometre scales”, explains May. There was enormous improvement in long-term stability as well. At the beginning, the samples only survived a few seconds before their power output collapsed. Following about a year of optimising, they now remain stable for over 40 hours. Further steps towards a long-term stability goal of 1000 hours are already underway.

“Forecasts indicate that the generation of hydrogen from sunlight using high-efficiency semiconductors could be economically competitive to fossil energy sources at efficiency levels of 15 per cent or more. This corresponds to a hydrogen price of about four US dollars per kilogram”, says Prof. Thomas Hannappel, from the photovoltaics group at TU Ilmenau, who was academic advisor for the work. Prof. Hans-Joachim Lewerenz from the Joint Center for Artificial Photosynthesis at the California Institute of Technology, who worked closely with May, said “We are nearly there. If we are successful in reducing the charge carrier losses at the interfaces somewhat more, we might be able to chemically store more than even 17 per cent of the incident solar energy in the form of hydrogen using this semiconductor system.” arö

Nature Communications, 6:8286, (DOI: 10.1038/ncomms9286): Efficient direct solar-to-hydrogen conversion by *in situ* interface transformation of a tandem structure; M. M. May et. al

## CHARACTERISING MICROSTRUCTURES IN POLY-CRYSTALLINE MATERIALS

A team from HZB and the Federal Institute for Materials Research and Testing (BAM) has shown how **Raman microspectroscopy** can be used to determine local crystal orientations of polycrystalline materials over large sample areas in an easy and cost-effective manner.

Most solid materials are of a polycrystalline nature. The way in which individual grains are oriented in the material can be relevant for its functional properties. To determine the corresponding orientation distributions over large specimen areas, a scanning electron microscope is typically used. The specimen surface needs to be prepared before it can be probed under vacuum by an electron beam and analysed using electron backscatter diffraction (EBSD). A team at HZB headed by Dr. Daniel Abou-Ras, together with Dr. Thomas Schmid from BAM, have shown that equivalent orientation distribution maps can be obtained by means of Raman microspectroscopy. This method needs only an optical microscopy set-up, no time-consuming specimen preparation, and can also be conducted under ambient conditions.

### Large section examined

The scientists used  $\text{CuInSe}_2$  thin films as a model system for their study. They showed that the experimental Raman intensities correspond well with the theoretical intensities calculated from the local orientations in the EBSD map. “The sample area was scanned by a laser beam using step

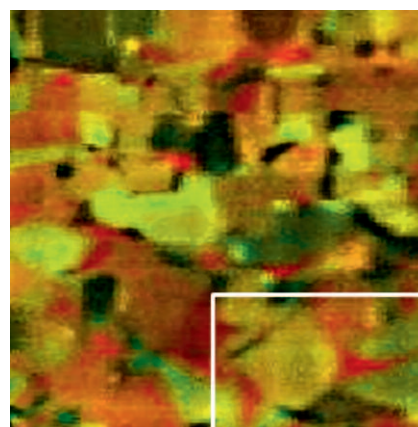
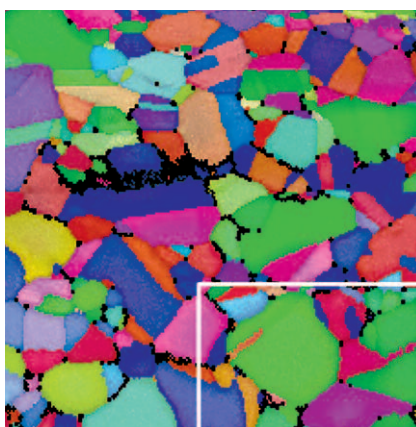

Left: Composite Raman intensity-distribution map on a polycrystalline  $\text{CuInSe}_2$  thin film. Right: EBSD orientation-distribution map from the same identical specimen position.

sizes of 200 nanometres. For such measurement conditions, the sample environment needs to be controlled carefully and kept stable for several hours,” explains Dr. Abou-Ras. The application of Raman microspectroscopy for orientation distribution analysis is possible in principle for all polycrystalline materials, whether they are inorganic or organic, as long as they are Raman-active.

*arö*

Scientific Reports 5, 18410 (2015) (DOI: 10.1038/srep18410): Orientation-distribution mapping of polycrystalline materials by Raman microspectroscopy; N. Schäfer, S. Levchenko, D. Abou-Ras and T. Schmid

### RAMAN SPECTROSCOPY

Raman spectroscopy, named after Indian physicist and Nobel laureate Chandrasekhara Venkata Raman, is based on the scattering behaviour of light by which molecular vibrations can be measured. Each type of molecule, or functional group thereof, produces uniquely distinguishable vibrations. A Raman spectrum can thus be interpreted

as a kind of characteristic “optical fingerprint” of a molecular species, allowing the identification of organic, inorganic or biological components. Raman microspectroscopy has proven especially valuable for studying biological samples. By combining a Raman set-up with a microscope, it is very easy to analyse structures at the submicrometre scale by taking non-invasive Raman images with chemical contrast and thus high molecular selectivity.

## HEMF: NEW HELMHOLTZ LABORATORY INFRASTRUCTURE

Six Helmholtz Centres are founding a shared infrastructure for **developing novel energy materials**. It will also be available to external users from universities and non-university institutes from Germany and abroad, as well as to industry.

In the summer of 2015, the Helmholtz Senate approved setting up a major infrastructure to synthesise and develop novel systems of materials for energy conversion and storage. Total funding will be 46 million euros for a five-year period until the end of 2020. The Helmholtz Energy Materials Foundry (HEMF) will be coordinated by the Helmholtz-Zentrum Berlin, while five additional Helmholtz Centres are participating in the design, planning, and set-up: the German Aerospace Center (DLR),



With the new Energy Materials *In-situ* Laboratory (EMIL) at BESSY II, HZB is contributing its strengths in this field to the new laboratory platform HEMF.

Forschungszentrum Jülich (FZJ), Helmholtz-Zentrum Gees- hacht (HZG) for Materials and Coastal Research, Helmholtz-Zentrum Dresden-Rossendorf (HZDR), and the Karlsruhe Institute of Technology (KIT).

Several outstanding supplementary laboratories with unique equipment will be set up under HEMF at the six participating Helmholtz Centres. The scientific focus lies on the design of energy materials associated with solar fuels, solar cells and battery systems as well as thermo- electric and thermochemical materials. One research topic these applications share is the design of novel cata- lysts to be employed in energy conversion and storage.

### Broad range of capabilities

The range of capabilities of the HEMF platform extends from the design of novel materials systems to in-situ and in-operando analyses of processes for their synthesis, and three-dimensional nanostructuring of these materials to alter their properties in specific ways. In addition, methods will be developed to process novel materials, produce in- novative prototypes for specific applications and inves- tigate their properties and capabilities under continuous

loads. “This comprehensive approach enables the creation of efficient feedback loops between syn- thesis, characterisation and the evaluation of the end products. It will help us accelerate knowledge- based development”, says Prof. Anke Kaysser- Pyzalla, Scientific Director of HZB.

Synthesis laboratories are planned at HZB specifically for perovskite thin films, nanoparticles for catalysis and electrochemical storage, as well as facilities for the nanostructuralisation of materials. Methods will be developed for studying electrochemical processes at catalytic and heterogenous boundary surfaces by the Energy Materials *In-situ* Laboratory (EMIL) recently set up at HZB’s BESSY II facility. Moreover, testing labs are also being set up in order to study new systems of materials under actual operating conditions. HZB is

working together on this with the Max Planck Society’s Fritz Haber Institute in Berlin and the Max Planck Institute for Chemical Energy Conversion (CEC) in Mülheim.

### International user facility

The HEMF platform will be operated as an international user facility. The laboratories will be available to research teams from universities, non-university research institu- tions and industry. The coordination of user operations will be handled by HZB, which has a great deal of experience with this and has built up outstanding user services for its own large-scale facilities BESSY II and BER II. About 3,000 external personnel visiting for purposes of conducting measurements benefit from these services annually. HEMF builds on the model of Berkeley Labs in California, where a

Molecular Foundry was also set up as an infrastructure serving international user groups.

“HEMF will augment the Helmholtz Association’s expertise in synthesis of raw materials indispensable for the energy transition. The participating Helmholtz Centres will be able to add their research capabilities to this shared infrastructure so that we can make the energy we will need in the future available for use in a safe and simultaneously environ-

mentally friendly way. At the same time, the platform will draw attractive collaborating partners who are pursuing the same research goals”, Kaysser-Pyzalla explains further. This research plan’s unique order of magnitude will help the group of Helmholtz Centres contribute research and development on new energy materials – a contribution that will be comparably large and pioneering on an international scale as well. *arö*

## HZB STRENGTHENS CATALYSIS RESEARCH

Since 2016, the Einstein Foundation has been funding the new **Einstein Center for Catalysis (EC2)** in which the HZB, Technical University Berlin and selected non-university institutions in Berlin are participating.

Catalysis is a key topic of the future, whether for energy transition or for the processing of raw materials. If we want to utilise resources more efficiently and sustainably in the future, outstanding catalysts are indispensable. HZB is therefore strengthening its catalysis research and working with collaborating partners towards specific goals. Prof. Emad Aziz, head of the HZB Institute for Methods of Materials Research, is taking part in setting up the institution. His team contributes particular expertise in the analytics of ultrafast processes in catalytic reactions. Methods will be developed at the Einstein Center for Catalysis (EC2) that facilitate deeper investigation of chemical and biological catalysts. The dynamics of catalysis processes in particular will be better understood with these methods. “The formation of the inter-institutional Einstein Center for Catalysis is a real milestone for catalysis research in Berlin. HZB will be involved even more strongly in catalysis research on Energy Materials in the future”, says Prof. Anke Kaysser-Pyzalla, Scientific Director of HZB.

### BESSY II provides outstanding analytics

The new Einstein Center builds on the UniCat (Unifying Concepts in Catalysis) Excellence Cluster at the Technische Universität Berlin. Besides HZB, the main partners in the new Einstein Center are the Fritz Haber Institute of the Max Planck Society, the Leibniz Institute for Molecular Pharmacology Berlin, the Leibniz Institute for Analytical Sciences Berlin, as well as the UniCat-BASF Joint Lab. The spokesperson of the new Einstein Center is Prof. Matthias Drieß from the Organometallic Chemistry and Inorganic Materials branch of the Department of Chemistry, TU Berlin. “In order to be able to determine the dynamics of active reaction



Top-level analytics are being done at BESSY II to develop new methods for studying the electronic structure of catalytically active molecules.

centers with a high degree of temporal as well as spatial resolution, we need HZB as a partner with its outstanding analytics at BESSY II”, says Drieß.

The HZB Institute for Methods of Material Development is working on new experimental methods that utilise light in the X-ray or extreme UV regions. “These methods permit us to make new tools available in order to investigate the electronic structure of catalytic molecules and the ultrafast processes that occur during catalysis under realistic conditions such as room temperature and standard atmospheric pressure”, explains Aziz: “Dr. Tristan Petit and Dr. Annika Bande, whose groups are supported by Freigeist grants from the Volkswagen Foundation, will also benefit from the large network of catalysis research in Berlin.” The new Einstein Center is to be funded initially for five years ending in December 2020. *arö*

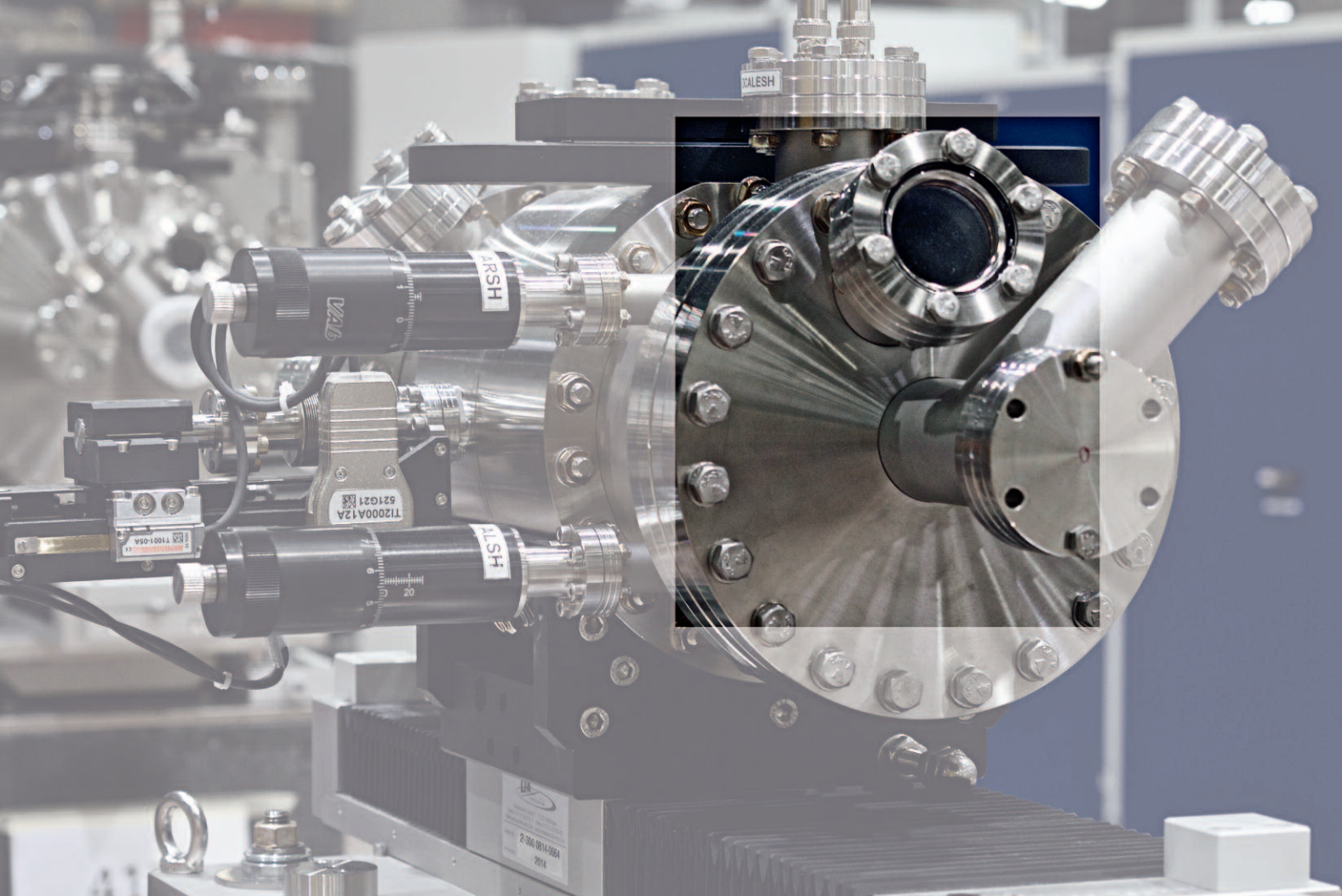

## DEVELOPING METHODS FOR RESEARCH WITH SOFT X-RAYS

**1,160 employees** were working at Helmholtz-Zentrum Berlin für Materialien und Energie in 2015, including trainees. 332 women were working at HZB, equating to 28.6 per cent of employees.

**15 young adults** received received a new training contract at HZB in 2015. At the end of 2015, a total of 50 young adults were working in 9 trained professions at HZB, including 12 Bachelors of Science in Computer Engineering in conjunction with the Berlin School of Economics and Law.

**447 ISI- and SCOPUS-cited papers** were published by HZB scientists in 2015 – of which 105 were in the programme Renewable Energies, 67 in the programme Energy Efficiency, Materials and Resources and 62 in the programme From Matter to Materials and Life.

**185 postgraduate students** were supervised at HZB in 2015. In total, 27 doctoral theses, one diploma thesis, 41 master theses, 31 bachelor theses and two student research papers were completed.

## FILMING CHANGES WITHIN MATERIALS

Since the end of 2015, the EDDI beamline at BESSY II can be used to obtain high-resolution three-dimensional images of the microscopic structure of samples. **X-ray diffraction (energy-dispersive diffraction)** can simultaneously be carried out to draw conclusions about the crystal structure of the material.

Dr. Catalina Jiménez and Dr. Francisco García-Moreno, in charge of this option at the beamline, suggested this innovation in late 2013 and have now successfully implemented it. EDDI uses the complete energy spectrum of BESSY II X-ray pulses to rapidly create diffraction images. They provide insight into the lattice structure and separation of atoms in the sample. However, some of the X-rays travel unobstructed through the sample without being diffracted. This beam can now be transformed by a scintillator crystal into visible light and recorded by a camera. By rotating the sample, one obtains three-dimensional images in a process called tomography. Realising this was not trivial. The sensor head with the scintillator crystal had to be situated close to the sample without hindering the path of the diffracted beam. “We worked closely on this with the HZB workshop”, García-Moreno reports.

### Up to four tomographic images per second

The sample table can be rotated and is equipped with sliding electrical contacts so that batteries can be investigated during their charging process, for example. There are also various ways to heat or cool the sample while measurements are being taken. “For example, we can observe changes that take place in batteries while charging, how hydrogen becomes deposited in steel, as well as investigating many other questions to do with energy materials”, explains Jiménez. In the meantime, the team has demonstrated that the performance is even higher than expected. “We originally assumed that one complete tomographic image of a sample would take several seconds. But now we are even managing to do a diffraction spectrum simultaneously with up to

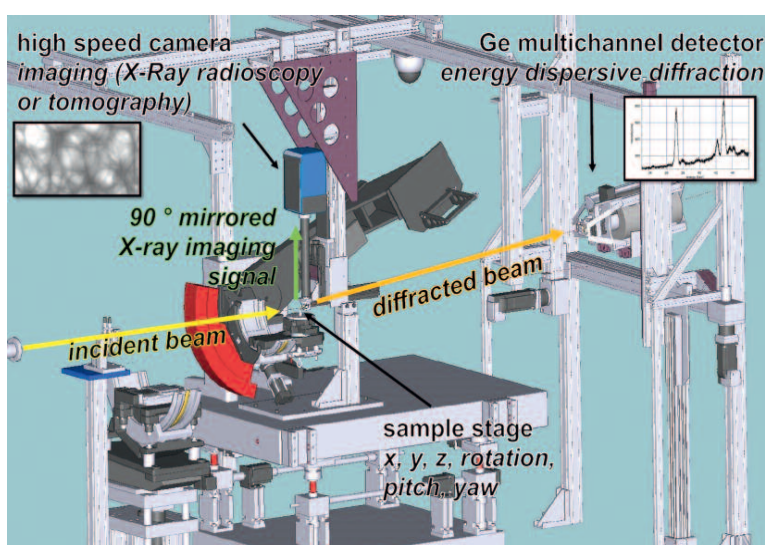

Sketch of the new set-up at EDDI. The high-speed camera (blue box) is on top of the sample holder.

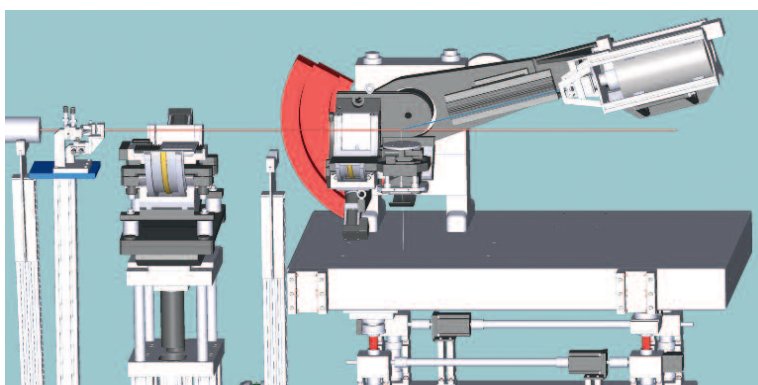

one complete tomographic image per second, or up to four tomographic images per second by themselves. That means we can observe and film rapid changes in samples and correlate them with the corresponding phases in the material,” says García-Moreno. This feature has already been brought online in user operations and the first user groups with interesting proposals have already applied for beam time.

arö

## THE TRAIL IS BLAZED FOR TENDER X-RAYS

**Novel optical gratings** developed largely by a research team at HZB tune into a region of the X-ray spectrum that has always been problematic for energy research.

The Berlin storage ring BESSY II delivers soft X-rays in a spectral range of up to 15 kilo-electronvolts of photon energy – a wide range for exploring phenomena in many different fields of research. Yet one region of this energy spectrum has always had to be largely omitted from experiments. “The energy range between two and five kilo-electronvolts has always been practically unusable in science because we have never had optical elements efficient enough for the experimental requirements,” says Prof. Dr. Alexei Erko, head of the Institute for Nanometre Optics and Technology (FG-INT) at HZB. The scientists have recently dubbed this “white patch” in the spectrum of the synchrotron radiation source “tender X-rays”.

### Successful combination of two different technical approaches

A team of researchers led by Alexei Erko has now managed to fill the gap in suitable optical components needed to focus the beam and filter out certain frequencies in the tender X-ray range. Together with colleagues from the Dutch University of Twente and Tongji University in Shanghai, they developed a novel structure that now makes this elusive spectral range useful for scientific experiments. “We did so by combining two different technological approaches into one optical element,” explains Erko. They combined optical “multilayers” consisting of different materials in sandwich-like form, with a so-called blazed grating. The surface of this specially developed component has a zigzagged or sawtooth structure.

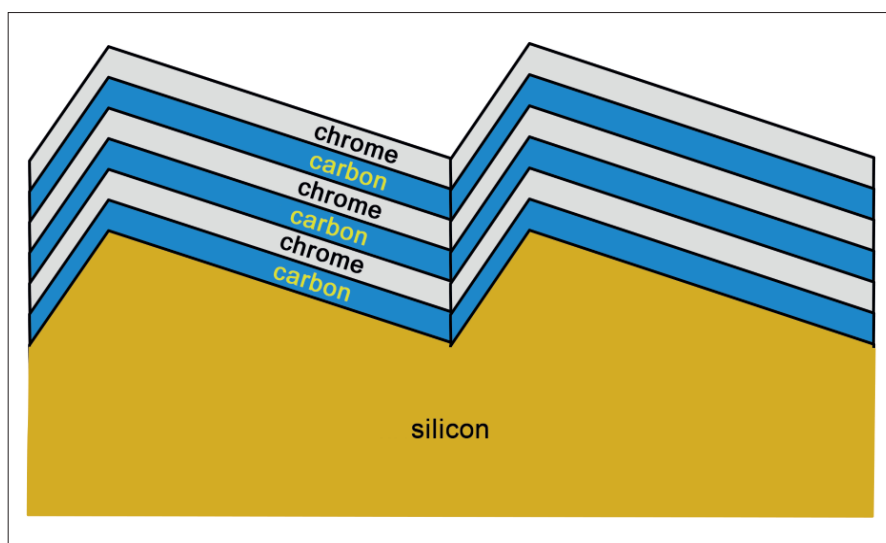

Combining chrome-carbon optical multilayers on a silicon wafer with a blazed grating a few nanometres in size allows the use of tender X-rays in scientific research.

The HZB researchers are the only ones in the world who can produce the fine sawtooth structures at such high quality. The Berlin research centre inherited the production systems and expertise from optical giant Carl Zeiss when the company ceased its production of blazed gratings in 2008. The scientists in Twente and Shanghai, in turn, are experts in the high-precision production of the ultrathin multilayers of sandwiched materials.

### Complex calculation of the optimal size of grating elements

The combination of these two technologies makes it possible for the first time to produce highly efficient grating elements for the otherwise unmanageable energy range of tender X-rays. Physicist Dr. Friedmar Senf, formerly group head at the FG-INT and currently a visiting researcher at the HZB Institute for Methods and Instrumentation for Research with Synchrotron Radiation, ran complex simulations to determine the best way to combine the



sawtooth shape of the blazed grating with multilayers to achieve optimal results. He calculated the theoretically optimal dimensions and material parameters of the grating and discovered that a combination of chromium and carbon is especially suitable for the multilayers – two chemical elements whose electronic absorption edges are far outside the energy range of tender X-rays.

Senf presented his findings and initial measurement results publically at the Second Swedish-German Workshop on X-Ray Optics hosted by HZB in Berlin at the end of April 2015 – arousing great interest among the participants of the event. Since then, further gratings and multilayers have been produced and tested. To make their blazed gratings, the scientists at HZB coated highly polished silicon wafers with 300 nanometres of gold. They then etched sawtooth grooves a few nanometres deep into this gold layer using a diamond tip. They worked under incredibly stringent process conditions: “To produce the very fine structures uniformly, an extremely stable temperature was of the utmost importance,” Alexei Erko reports. The temperature during production was not allowed to fluctuate by more than one hundredth of a degree Celsius.

#### Highly efficient at a photon energy of four kilo-electronvolts

Etching the approximately 60-millimetre long, 30-millimetre wide grating surface generally took five to ten days, over which the temperature had to be kept stable. Next, layer upon layer of carbon and chromium were alternately vapour-deposited, at a precision of one-tenth of a nanometre thickness. The results of this elaborate production process are optical elements with so far unique properties. Tests on a development test bed at BESSY II confirm that relatively little energy is lost upon the diffraction of tender X-ray light on a blazed multilayer structure. The efficiency is around 55 per cent at a photon energy of four kilo-electronvolts. “No other optical component is even remotely as efficient at this photon energy,” Erko stresses. “Similar conventional gratings only reach an efficiency of two to three per cent.” The researchers came across another outstanding property of the novel grating structure: the higher orders of diffraction that typically occur on conventional gratings, disrupting the experiments, hardly occur at all as X-ray light reflects off the blazed multilayer grating. “This makes the grating structure interesting for experiments at low energies as well, of below one kilo-electronvolt, where high orders of diffraction are especially disruptive,” says Erko, who describes this as a breakthrough. “With this development, it can now certainly be said that the storage ring BESSY II can be used over a very wide spectral range at optimum quality.”

“As the next step, we will produce larger gratings,” says Friedmar Senf – large enough for use in real-world science

at synchrotron radiation sources. “We next plan to equip an X-ray microscopy beamline with a large blazed multilayer grating that is currently being built to operate at a photon energy of three kilo-electronvolts,” the physicist announces. His calculations prove that such large blazed multilayer gratings can also be produced without trouble. The highly efficient elements will also one day be integrated into the Energy Materials In-situ Laboratory (EMIL) at BESSY II.

#### Especially promising energy window for experimental studies

“The demand for the novel gratings is huge because they make an especially promising energy window accessible for experimental studies with X-ray light,” says Alexei Erko. It is namely the very spectral range in which the electronic absorption edges of many important chemical elements in energy research lie – such as sulphur, phosphorus, aluminium and silicon. These play a crucial role, for example, in the development of novel energy materials. The research for which the HZB team and partners have now opened the door raises hopes for exciting new insights and important advances in the conversion and storage of energy.

*rb*

2nd German-Swedish Workshop on X-ray Optics, Berlin, 28th-30th April 2015: Performance of a blazed multilayer grating for energies between 800 eV and 5.000 eV, calculations and measurements; F. Senf et al.

#### IN BRIEF

- The energy range of soft X-rays between two and five kilo-electronvolts has always been practically unusable in science for want of suitable optical elements.
- An international research team led by Dr. Alexei Erko of HZB succeeded in developing the necessary optical elements by combining two known technologies.
- To do so, they deposited multiple layers of chromium and carbon onto an optical material etched into an ultra-fine sawtooth pattern. Dr. Friedmar Senf had previously calculated the optimal size of the grating.
- In the next step, the gratings will be made available for scientific research. This opens up new possibilities in the development of energy materials.

## HOW TO FLOW ULTRATHIN WATER LAYERS

Scientists from the Max Born Institute for Nonlinear Optics and Short Pulse Spectroscopy, the HZB and the Max Planck Institute for Dynamics and Self-Organisation have demonstrated the successful implementation of a **liquid flatjet for XAS transmission measurements** in the soft X-ray regime.

Element-specific X-ray methods play a key role in determining the atomic structure and composition of matter and functional materials. X-ray spectroscopy is sensitive to the oxidation state, the distances, coordination number and species of the atoms immediately surrounding the selected element. A large variety of X-ray

transmission, absorption cross-sections demand sample thicknesses in the micrometre and submicrometre range (1 micrometre = one millionth of a metre). Alternatively, if secondary signals such as X-ray fluorescence are measured, the experiment is limited to comparably large solute concentrations.

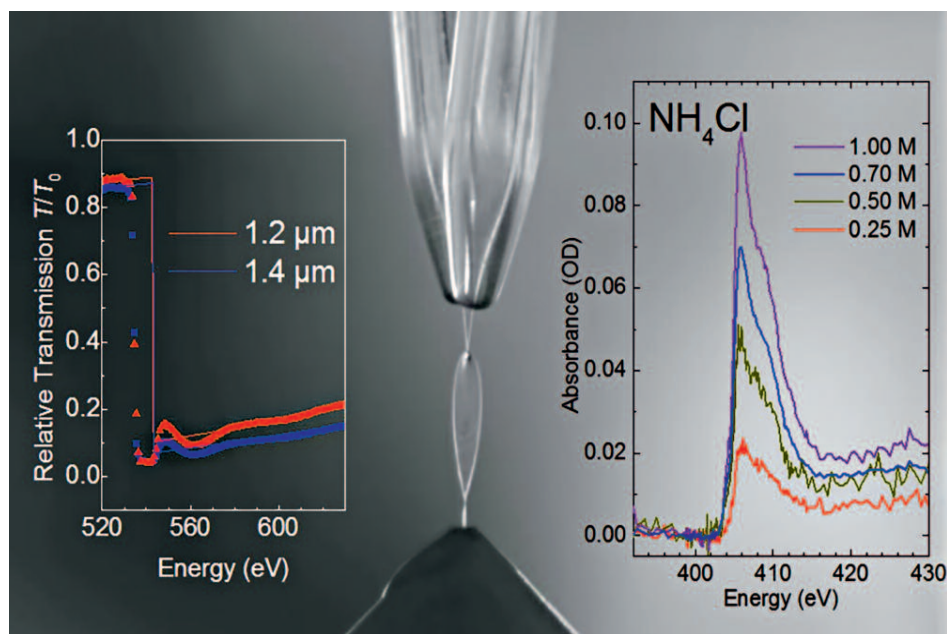

Liquid flatjet system, showing the two nozzles from which two impinging single jets form a 1 mm wide and 5 mm long liquid water sheet with a thickness of 1–2  $\mu\text{m}$  as determined by measuring the transmission at the oxygen K absorption edge (left), with which XAS measurements in transmission can be made on aqueous solutions, as exemplified with the nitrogen K absorption edge spectrum of ammoniumchloride (right).

spectroscopic techniques have been applied to gas-phase, bulk liquid or solid-state samples, or have been used to probe molecular systems at interfaces. X-ray spectroscopy is predominantly done at large-scale synchrotron facilities, or in more recent years with X-ray free electron lasers, probing steady-state and time-resolved material properties. Solution-phase soft-x-ray absorption spectroscopy (XAS, energy range approximately from 0.2 to 1.5 keV) is not an easy method: experiments need to be done under vacuum conditions, an environment obviously incompatible with the high vapour pressure of water. Furthermore, if measured in

### Application of a phenomenon of fluid dynamics

Using sample cells with thin membrane windows enables control of appropriate sample thicknesses. But sample degradation upon X-ray illumination (or upon pump laser illumination in time-resolved experiments) makes this approach disadvantageous for photolabile molecular systems. Sample refreshment is possible with a liquid jet, generated by pumping a solution through a nozzle with a small orifice into the vacuum chamber. Single liquid jets, however, have difficulties to implement the required (sub)micron thicknesses.

A collaboration between scientists from the Max Born Institute for Nonlinear

Optics and Short Pulse Spectroscopy, the Helmholtz-Zentrum Berlin and the Max Planck Institute for Dynamics and Self-Organisation has now demonstrated the successful implementation of a liquid flatjet with a thickness in the  $\mu\text{m}$  range, allowing for XAS transmission measurements in the soft-X-ray regime. Here a phenomenon well known in the field of fluid dynamics has been applied: by obliquely colliding two identical laminar jets, the liquid expands radially, generating a sheet in the form of a leaf, bounded by a thicker rim, orthogonal to the plane of the impinging jets.

### Measurements at BESSY II

The novel aspect here is that a liquid water flatjet has been demonstrated with thicknesses in the range of a few micrometers, stable for tens to hundreds of minutes, fully operational under vacuum conditions (lower than  $10^{-3}$  mbar). For the first time, soft X-ray absorption spectra of a liquid sample could be measured in transmission without any membrane. The X-ray measurements were performed at

the soft X-ray synchrotron facility BESSYII of HZB. This technological breakthrough opens up new frontiers in steady-state and time-resolved soft-X-ray spectroscopy of solution-phase systems. *arö*

Structural Dynamics 2, 054301 (2015); (DOI: 10.1063/1.4928715):  
A liquid flatjet system for solution phase soft-x-ray spectroscopy;  
M. Ekimova, W. Quevedo, M. Faubel, P. Wernet and T. J. Nibbering

## SPECIFIC PULSE SELECTION AT BESSY II

A joint team of physicists and engineers from Forschungszentrum Jülich, MPI of Microstructure Physics and HZB has developed an **extremely fast rotating “MHz-pulse selector”**. It is at the core of the Uppsala Berlin joint Lab to extract the hybrid bunch within the 200 nanosecond ion clearing gap.

Ultrashort X-ray flashes as used at one of the more than 50 beamlines at BESSY II are usually generated in electron storage rings by circulating short electron bunches. However, many experiments don't actually need all of the up to 400 pulses per turn but only one of them. One solution could consist of a wheel equipped with a hole, synchronised with the electron motion, to allow only one pulse to pass through the hole while the others are blocked. But this is not as easy as it sounds. The wheel has to be pretty fast because the pulse arrives every 800 nanoseconds (ns), which means that we are talking about triple sound velocity of roughly one kilometre per second, meaning enormous stress on the material.

Indeed, this kind of device has been developed by a joint team of physicists and engineers from Forschungszentrum Jülich, Max-Planck-Institute of Microstructure Physics Halle/S. and HZB, and is now available for regular use at a BESSY II beamline. The device, a “MHz-pulse selector”, consists of a wheel made of a special aluminium alloy which has tiny slits of  $70\ \mu\text{m}$  in width at its outer rim. They move frictionlessly in a vacuum at triple sound velocity perpendicular to the beam. A high-precision “cruise control” keeps the arrival time of the holes with respect to the beam within a margin of two nanoseconds and makes sure that only one X-ray pulse out of BESSY II's pulse train arrives at the experiment.

Experimenters at this beamline may now select what they want: a single pulse mode or the quasi-continuous X-ray

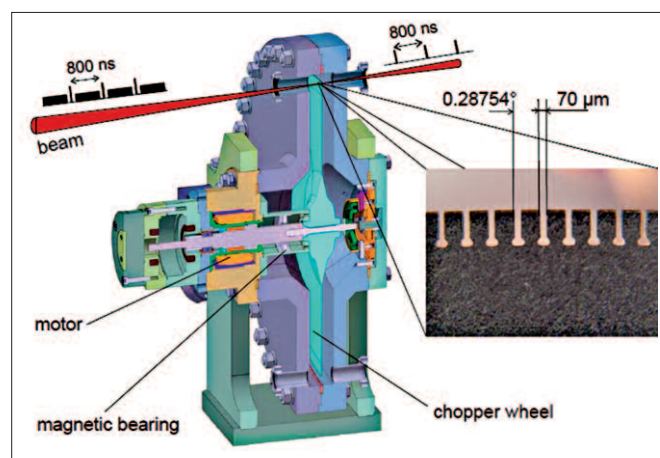

Sketch of the “MHz-pulse selector” which moves frictionless in a vacuum at triple sound velocity perpendicular to the beam.

beam. “This kind of pulse selection will be particularly important for the upgrade project BESSY-VSR at HZB that will provide a number of selectable X-ray pulses at different pulse length,” Dr. Karsten Holldack from the HZB Institute Methods and Instrumentation for Synchrotron Radiation Research explains. *KH/arö*

Optics Letters, Vol. 40, 10, (2015); (DOI: 10.1364/OL.40.002265):  
Phase-locked MHz pulse selector for X-ray sources; D. F. Förster,  
B. Lindenau, M. Leyendecker, F. Janssen, C. Winkler, F. O. Schumann,  
J. Kirschner, K. Holldack and A. Föhlich

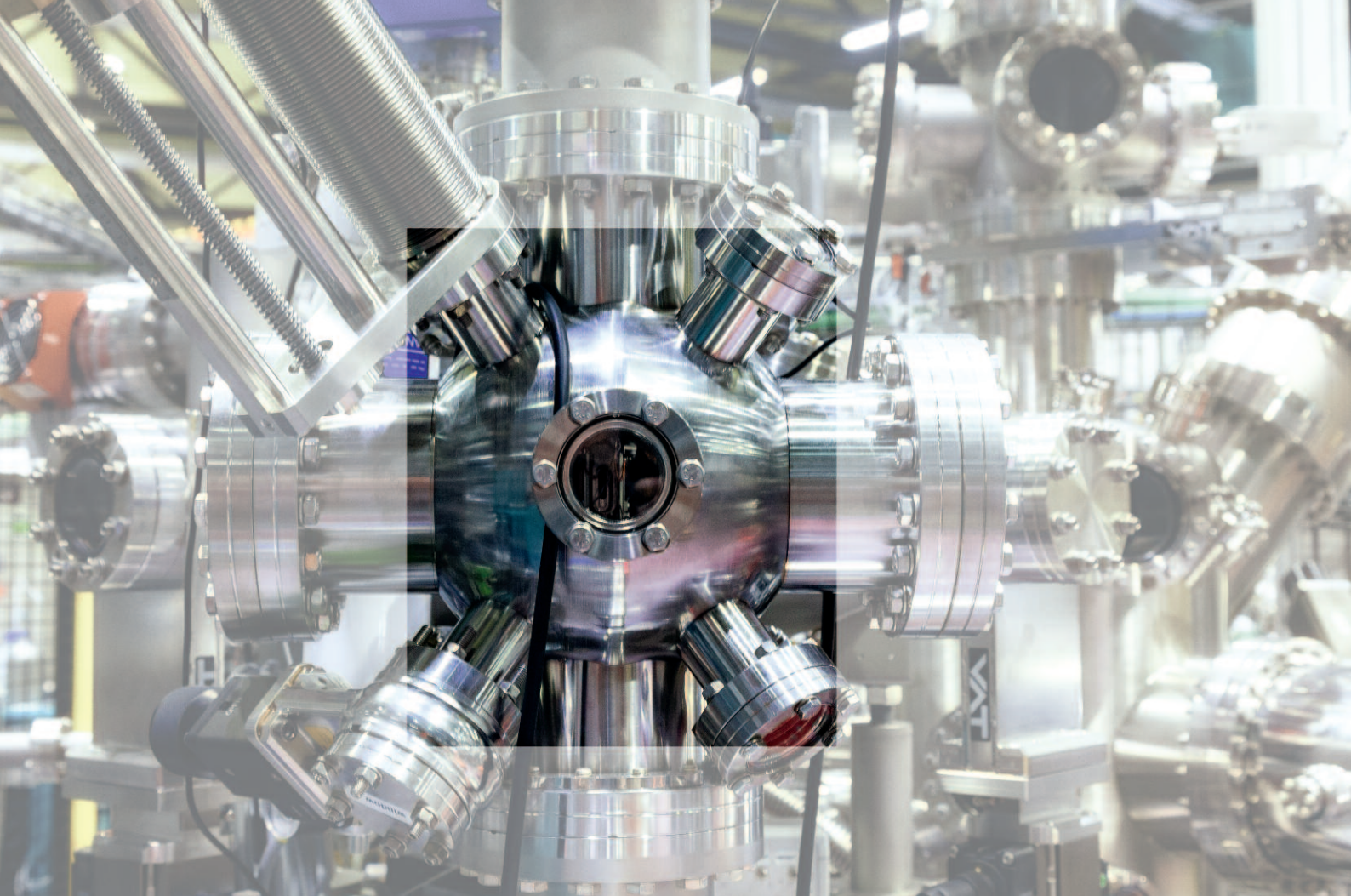

## ACCELERATOR RESEARCH AND DEVELOPMENT

**A core strategic goal** of HZB for the medium term is to upgrade the photon source BESSY II into a “variable-pulse-length storage ring (BESSY VSR)”.

**BESSY II** has provided a new standard fill pattern since July 2015. This gives the user community new possibilities for time-resolved experiments in multi-bunch mode.

**With the installation** of two new cavities and two more emitters in the storage ring and on the synchrotron, the cavity replacements and conversion to solid-state emitters (semiconductor emitters) were completed. In 2015, the LowDose Photoemission Station,  $\mu$ mRIXS, CXS stations and XPP-KMC-3 beamline went online for user operation.

**BESSY-VSR** will allow researchers to perform static and dynamic experiments practically simultaneously. In 2015, other essential technical problems were solved such as “pulse picking” and the ability to circulate electron packets on different trajectories.

In 2015, HZB took on an important task of technology exploration for next-generation photon sources **with the project BERLinPro**. The aim of the project is to demonstrate the feasibility of an energy recovery linac for high medium electron beams and small emittances. Construction of the building commenced in 2015.

## ACCELERATOR PHYSICISTS ARE LOOKING TO BERLIN

In the autumn of 2015, construction commenced for the new accelerator hall of bERLinPro, where a compact test facility for an **energy-recovery linac** is being built. HZB thus took another important step on the path to realising a technologically unique project.

The scientific director of HZB, Prof. Anke Kaysser-Pyzalla, praised the international cooperation which, she says, is essential for the development of such new, fascinating accelerator technology. In particular, she thanked the grant authorities for their involvement and support. Prof. Andreas Jankowiak, head of the HZB Institute for Accelerator Physics and project manager of bERLinPro, stressed that HZB was truly breaking new ground with the project, and that many accelerator physicists will be looking keenly to Berlin in the near future. Together with the team of Prof. Jens Knobloch, head of the HZB Institute SRF - Science and Technology, his institute intends to build a linear accelerator with energy recovery capability in Adlershof. The plan is to create a test facility that encompasses all key components and demonstrates the general applicability of the technology for future large facilities. HZB researchers will use the test facility to study the parameter space in order to operate such accelerator facilities optimally at ultra-high intensities for research.

### Full operation of the test facility planned for 2020

Starting in 2017, the components for the ERL will be built up incrementally in the accelerator hall and, starting in 2018, the first beam tests will commence with the aim of bringing the facility into full operation by 2020. Andreas Jankowiak emphasises: “The actual challenge is to develop the various components and new methods. So, it is especially true in this case that the journey is the destination.”

Construction of the accelerator hall is an equally Herculean task. The planners must meet all radiation protection requirements and guarantee adequate cooling for the superconducting test accelerator. Constanze Tibes of the supervising architecture firm DGI Bauwerk adds that the plans are extremely complex and without precedent. She describes the accelerator hall, being built under the management of the HZB Construction Department, as a “one of a kind for science”.

### Developing new components and methods

With bERLinPro, a test facility is being created for ultra-high currents and ultra-low emittances. The concept of the



Groundbreaking ceremony for the new accelerator hall of bERLinPro (left to right): Prof. Dr. Jens Knobloch, Thomas Frederking, Prof. Dr. Anke Kaysser-Pyzalla, Prof. Dr. Andreas Jankowiak and Constanze Tibes. The topping-out ceremony was celebrated in the summer of 2016.

energy recovery linac dates back to the 1960s. However, more than 30 years would go by before the first facilities went online at the beginning of 2000, for example those at Jefferson Lab, the Japan Atomic Energy Research Institute, ALICE at the Daresbury Laboratory, and NovoFEL of the Budker Institute of Nuclear Physics in Novosibirsk. “We understand the physics of these systems better now, and have the prerequisites for solving the associated problems,” Jankowiak says. Among other things, entirely new components have to be developed such as a high-brilliance, high-frequency photoelectron source and superconducting cavities for continuous wave (CW) operation at extremely high currents.

This developmental work has been done in national and international collaborations with the involvement, among others, of DESY, Helmholtz-Zentrum Dresden-Rossendorf, the Max Born Institute, Jefferson Lab, Brookhaven National Lab, Cornell University and the Budker Institute. Also involved are German universities in Dortmund, Rostock, Mainz and Berlin.

sz

## COSTLY MAGNETIC TROUBLEMAKERS

**Superconducting materials** prevent costly heat losses in particle accelerators. Yet there is still a residual loss of energy. HZB researchers have now explained why this is so.

In particle accelerators, electrically charged particles are brought to high speeds to make them produce the precious radiation used for research. This is done with the help of “cavities” – closed chambers in which electromagnetic oscillations are excited, which can be amplified using resonance. In conventional accelerators, these are made of copper which possesses especially high electric conductivity. There is, however, a certain disadvantage: the metal tends to heat up while the accelerator is in operation, and must be cooled at great expense.

Top: Schematic representation of a cavity in which electromagnetic oscillations are excited and amplified. Thermoelectric currents flowing through it (bottom) produce weak magnetic fields that result in energy losses.

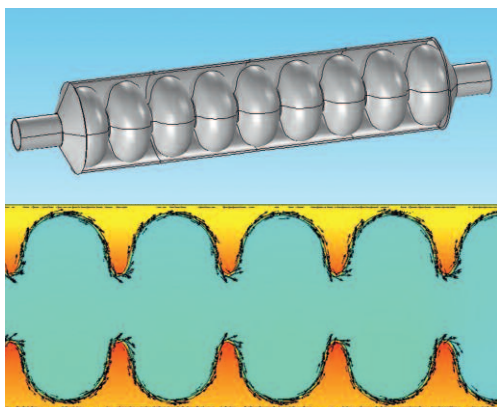

Resonators for modern facilities are therefore made of a superconducting material instead – typically niobium, which loses all electrical resistance to direct current at a temperature of about nine Kelvin (minus 264 °C). If alternating current flows through the material, then a weak resistance remains even below the so-called transition temperature. At a frequency of 1.5 gigahertz, this resistance is only about a ten-millionth of the resistance of copper, and continues to diminish as the temperature approaches absolute zero. “Aside from this, another residual resistance persists, the cause of which has so far not been fully understood,” says Prof. Jens Knobloch, head of the HZB Institute SRF – Science and Technology. With resistance reduced essentially to zero, the thermal losses also disappear, at least in theory. In reality, the last little bit of residual resistance even in a superconducting

cavity continues to eat up valuable energy. This has expensive consequences: “In a large accelerator facility with many superconducting high-frequency cavities, the costs for the liquid helium system that cools the cavities alone amount to several dozen million euros. Each year, there are many millions of euros in additional costs for operation.” An important aim of the facility operator is therefore to reduce the losses by using the highest-quality resonators possible. Jens Knobloch and his team at HZB have taken a crucial step in this direction: the researchers managed to explain the cause of the residual resistance in superconducting cavities. “Because the niobium cavity is welded into a titanium tank, thermocouples are created where the two metals meet as they cool,” explains Julia-Marie Köszegi, who investigated this effect together with her teammate Dr. Oliver Kugeler. “The different temperatures of the two cavity ends during cooling cause a thermoelectric current to flow through the cavity,” says Kugeler. “This produces weak magnetic fields which become ‘frozen’ in the superconducting material – that is the cause of the energy losses.”

### Paradox resolved in the laws of physics

The researchers’ aim was to demonstrate this scenario experimentally and in computer simulations. To do so, they alternately cooled and heated a niobium resonance chamber multiple times and precisely measured its losses. “We were able to clearly demonstrate the correlation between temperature difference and loss,” Köszegi reports. The scientists even managed to resolve an apparent paradox in the laws of physics: in a cylindrical cavity, no magnetic field ought to arise on the inner wall of the cavity at all, due to its symmetry. “Yet because the cooling does not happen uniformly, but rather proceeds from bottom to top, the symmetry is broken,” institute director Jens Knobloch explains. The researchers furthermore determined the thermoelectric properties of niobium and titanium. This data, together with measurements on the temperature gradient along the cavity, went into computer simulations of the cooling process. The results of the simulation were

consistent with the direct measurements of the magnetic fields in the cavity – which were an enormous experimental challenge. “We have thus demonstrated that our theory is plausible,” Knobloch continues. “This makes it clear how great a role magnetic effects play in a superconducting cavity.” Their influence had long been underestimated. The results have enormous repercussions for the design of particle accelerators. “They offer a chance to save a lot of money,” says Knobloch. “Because if you know what is

happening in a material, then you can reduce energy losses in a targeted manner.” As one would expect, the results have caused quite a sensation in the scientific community and have encouraged other groups to do more research. *rb*

Phys. Rev. ST Accel. Beams 18 (DOI: 10.1103/PhysRevSTAB.18.042001): High-Q operation of superconducting rf cavities: Potential impact of thermocurrents on the rf surface resistance; J.-M. Vogt, O. Kugeler and J. Knobloch

## BESSY II GETS SECOND LANE

The particle accelerator team at HZB can now operate the synchrotron radiation source with two simultaneous electron paths. Packets of electrons can travel along it and emit intense light pulses at the experiment stations. HZB is the first to enter this new territory and at the same time has reached another **milestone in its BESSY-VSR project.**

In simplest terms, the path of the electrons in BESSY II is comparable to a highway with only a single lane up to now. The packets of electrons in the storage ring would correspond to convoys of cars that travel along this circular route while flashing their headlights at specific locations to provide the experiments along the beamlines with pulses of light. A team from the HZB Institute for Accelerator Physics has now established a second lane in which individual packets of electrons circulate. Using special settings of the magnetic focussing componentry, an additional orbit is formed within the storage ring in addition to the original one, winding around it. “We are able to precisely monitor and control the packets of electrons in this way and to implement basically any desired fill pattern”, says Prof. Dr. Andreas Jankowiak, who heads the HZB Institute for Accelerator Physics. The physicists refer to the sequence of the electron packets and intervals between them as the fill pattern. Staying with the analogy of a highway, a fill pattern could be regarded as individual cars or convoys, all separated at specific intervals, for example.

### More options for the science community

The newly developed orbital mode has already been stably implemented and initial tests at the experiment stations of the beamlines show promising results. This advance will considerably broaden the features offered by BESSY II to the user community, and extend the methods available today for selecting individual light pulses. For example, one could use the new technique to fill the primary electron path with groups of electron packets that produce light

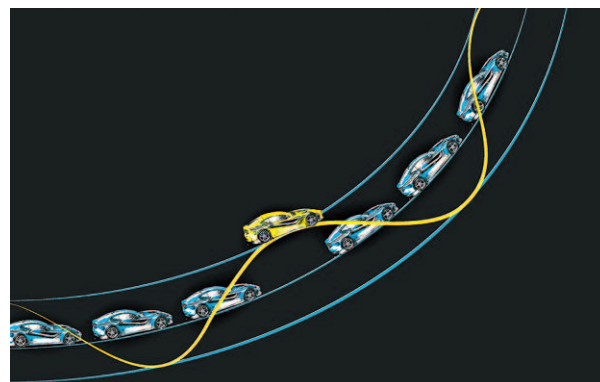

The picture illustrates a hypothetical highway with the second path winding around the first one. Experimenters at the beamlines could then either use the dense sequence of light pulses from the primary electron path or select individual light pulses from the secondary orbital track.

pulses in rapid succession, while placing individual electron packets in the secondary orbit. These would then generate light pulses with longer intervals, which is ideal for quite a few experiments. Andreas Jankowiak adds: “This advance is immediately of use for us in our BESSY-VSR (variable storage ring) upgrade project as well. We expect to be able to generate ultra-short as well as longer light pulses with BESSY-VSR, which we could then insert into the two different electron paths.” *arö*

Proceedings of IPAC 2015, ISBN 978-3-95450-168-7, Transverse resonance island buckets at the MLS and BESSY II; M. Ries et. al

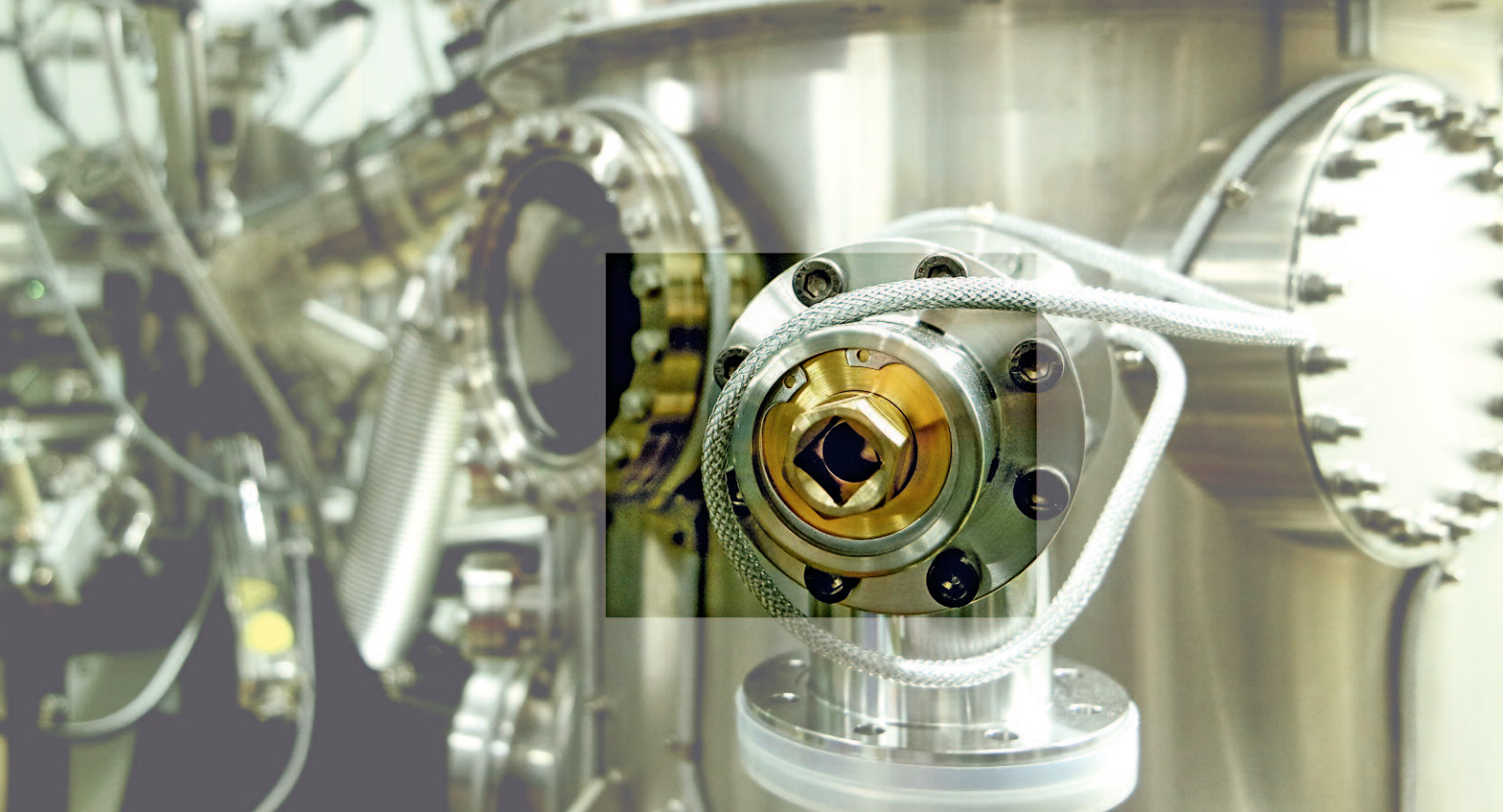

## HIGHLIGHTS FROM USER EXPERIMENTS

**Nearly 2,500 user visits** to the electron storage ring BESSY II in Berlin-Adlershof were recorded in 2015. These were in the scope of 364 research groups from 27 countries. 567 external measuring campaigns were served with beamtime.

**251.67 operating days** were dedicated to scientific use of the storage ring facility BESSY II in 2015. This works out at a usage time of 6,040 hours, or 755 eight-hour shifts. That is 69 per cent availability. 880 hours, or 110 shifts, were reserved for accelerator studies.

**15,480 eight-hour shifts** were thus available at the 24 beam tubes with 35 experimental stations.

**2,913 shifts** went into upgrading the experimental stations and preparing the experiments. 912 shifts were dedicated to the exclusive use by the Physikalisch-Technische

Bundesanstalt (PTB). Accounting for the availability of individual beam tubes and experimental stations, 8,937 shifts were used by internal and external experimenters.

**77 per cent**, or 6,881.5 shifts, of the entire capacity available for scientific use that were actually used were used for external scientific projects. HZB scientists used 23 per cent, or 2,055.5 shifts for their in-house research.

**161.5 operating days** in 10 reactor cycles at 13 instruments was the availability of the neutron source BER II in 2015 after extensive retrofitting the year before. This equates to 2,099.5 instrument days. Another 4.5 operating days were reserved for recommissioning the reactor.



## EXPERIMENTS AT UP TO 26 TESLA

After around eight years' development and construction time, the **world's strongest magnet** for conducting neutron experiments is up and running at HZB. It produces a continuous magnetic field of up to 26 tesla. This opens up new research opportunities for users to pursue their many different questions.

**W**ith the High Field Magnet, researchers can bombard samples with neutrons inside extremely strong magnetic fields of up to 26 tesla in order to answer burning questions in physics, chemistry, biochemistry and the materials sciences. 26 tesla is a million times stronger than the Earth's magnetic field. For a long time, only 17 tesla had been possible. With its High Field Magnet inaugurated in the summer of 2015, HZB now offers a magnetic field 73 per cent stronger than before. Experiments using neutrons combined with strong magnetic fields are extremely useful in basic research. Magnetism is a fundamental property of all materials. Accordingly, magnetic fields are often a key parameter in experiments, alongside temperature and pressure, but only if they are strong enough. "High magnetic fields are already used everywhere. Researchers have observed new phenomena with them, but have not been able to explain them in detail. Now, at HZB, we can use high magnetic fields together with neutrons. This is a crucial advantage for understanding these phenomena," says scientific project head Bella Lake. With their experiments at the High Field Magnet the researchers want to achieve a better understanding of superconductors in order to improve their properties so that they will work at temperatures that are not so quite so low.

### International cooperation as a basis

Specialists from the USA, Italy, the Netherlands, Switzerland and Germany were involved in the construction of the HFM. Among others, the National High Magnetic Field Laboratory in Tallahassee, USA, developed the superconducting coil. The High Field Magnet works on a hybrid magnet principle. Superconducting coils are placed in series with normally conducting coils and operated under the same current of 2,000 amperes. This configuration reduces operating costs substantially compared to using only normally conducting magnets. The superconducting coil produces a magnetic field of up to 13 tesla. A complex infrastructure has had to be installed at the HZB for cooling and powering alone.



The team behind the High Field Magnet (from left to right): Daniel Süßmann, Prof. Dr. Bella Lake, Jochen Heinrich, Annette Daske, Wolf-Dieter Stein; (below, from left): Sebastian Gerischer, Dr. Hartmut Ehmler, Dr. Maciej Bartkowiak, Matthias Hoffmann, Dr. Norbert Stüßer, Robert Wahle, Dr. Peter Smeibidl and Stephan Kempfer.

### Finished as planned

Such an elaborate machine as the High Field Magnet can only be built within the time and cost constraints if the project is properly controlled. Annette Daske was responsible for the financial controlling of the HFM project. The business economist worked closely with Hartmut Ehmler. As project coordinator, Ehmler was responsible for both his conceptual work and the scheduling. Armed with their financial controlling data, project manager Peter Smeibidl was able to take alternative measures wherever necessary. Construction of the infrastructural facilities, for example, threatened to break the set budget, but the team was able to countersteer. Working with a new concept, the colleagues managed to achieve the same goal at the originally planned cost.

sz/hs

## A “DEVIL’S STAIRCASE” IN A SPIN-VALVE SYSTEM

A Japanese-German team observed at BESSY II how spins form unusual magnetic structures in a complex cobalt oxide single crystal. Such a material offers new perspectives for **spintronic applications**.

Complex magnetic structures are at the heart of promising new materials for devices in spintronics, a field of research aiming at more energy-efficient data storage and processing. A prominent example is the so-called spin valve, where the magnitude of the electrical current passing through a device is very sensitively dependent on its magnetic configuration. These configurations can be readily controlled by a magnetic field in artificial layer systems, resulting in the giant magnetoresistance effect (GMR), a discovery rewarded with the 2007 Nobel prize in physics to Albert Fert and Peter Grünberg. While classic GMR systems are composed of metallic layers, complex oxides often intrinsically provide layered structures with alternating magnetic configurations that can act as spin valves. Cobalt oxides are a class of materials that can exhibit a complex magnetic order that changes with increasing magnetic field, as for example indicated by distinct plateaux in the magnetization curve.

### Magnetic structures mapped

A Japanese team of researchers led by the group of Associate Professor Hiroki Wadati at the University of Tokyo has been successful in characterising the magnetic structures of the complex cobalt oxide  $\text{SrCo}_6\text{O}_{11}$  using the high-field diffractometer of BESSY II. Synthesis of new materials often results in tiny samples, and the crystals studied here had a diameter of only 0.2 mm. With the very high sensitivity of resonant diffraction, a core competence at the UE46\_PGM1 beamline of BESSY II, they managed to observe a fascinating type of spin order in the samples that are hardly visible to the naked eye. This order is called devil’s staircase, characterising a phenomenon where a plethora, in principle even an infinite number, of so-called commensurate superstructures – magnetic configurations in the present case – can be realised by tuning an external parameter, e.g., a magnetic field. This exceeds the characteristic of a spin valve and may open new paths in spintronics. The research was carried out in close cooperation with scientists from the Leibniz Institute for Solid State and Materials Research Dresden and HZB. *Eugen Weschke*

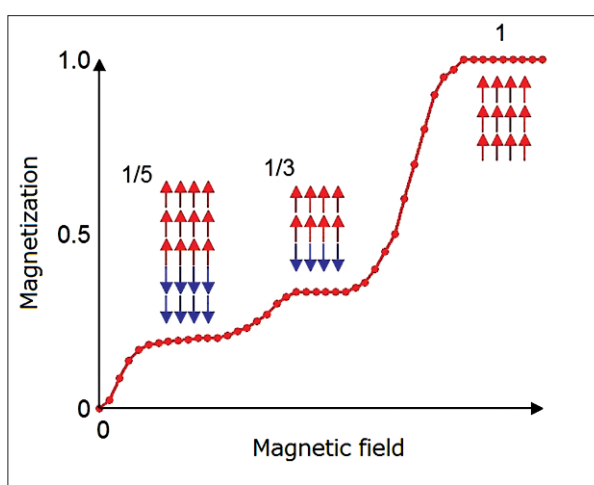

Hexagonal single crystal of  $\text{SrCo}_6\text{O}_{11}$ , with a sample diameter of approximately 0.2 millimetres.

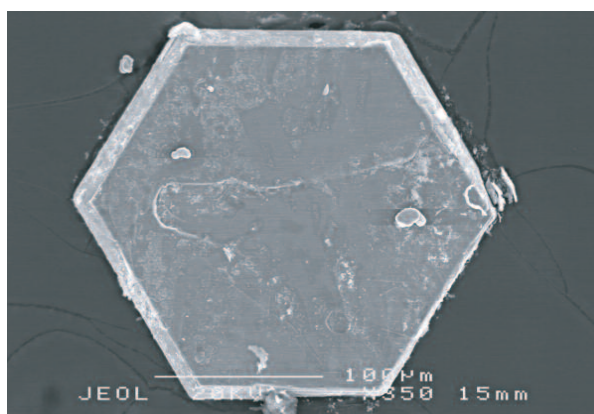

The material exhibits a distinct magnetisation plateau connected with different spin configurations.

Physical Review Letters 114, 236403 (DOI: 10.1103/PhysRevLett.114.236403): Observation of a Devil’s Staircase in the Novel Spin-Valve System  $\text{SrCo}_6\text{O}_{11}$ ; T. Matsuda, S. Partzsch, T. Tsuyama, E. Schierle, E. Weschke, J. Geck, T. Saito, S. Ishiwata, Y. Tokura, and H. Wadati

## LUMINOUS HYBRID

Light-emitting semiconductors are ideal for use in displays and in high-speed data transmission and processing. Yet the conventionally used materials don't actually make their light available all that easily. Researchers at HZB, the Humboldt University in Berlin and the Georgia Institute of Technology have shown what could work better in future: a **clever combination with organic molecules** that have their own semiconducting properties.

**H**olographic displays producing three-dimensional images; digital medical imaging technologies providing a detailed view into the human body; ultrafast digital optical communication – we have no shortage of applications for light-emitting semiconductor materials. Yet there is still a critical limitation: when it comes to the most commonly used inorganic semiconductors such as silicon and gallium nitride, the light yield emitted upon electrical excitation is still low. The greater part of the excitation energy is simply lost to other processes. Also, the conventional materials emit light

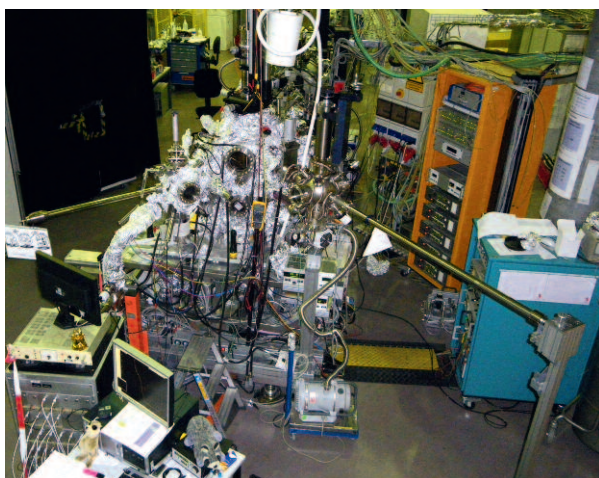

The hybrid semiconductor experiments were performed at the end station Surl-Cat (Surface Investigation and Catalysis) of BESSY II.

in a narrow choice of wavelengths, so there is not much scope for varying the colour of the light. “One alternative is organic semiconductors,” says Prof. Dr. Norbert Koch, head of the Molecular Systems work group at HZB. They show their strengths exactly where inorganic materials show their weaknesses. Many organic semiconductors are excellent optical emitters, producing a high yield of light over a wide, variable frequency range. “The disadvantage of these semiconductors is the low mobility of the charge carriers, which organic semiconductors have

precious few of in the first place,” says Koch. This makes organic materials unsuitable for use in electronics-based data transmission, for example, where high speeds are a priority. Conversely, this is exactly where inorganic semiconductors shine.

### Combination of organic and inorganic semiconductors

So the obvious question is, what if we combine inorganic semiconductors with organic ones? “This way, the advantages of both materials can be added while the disadvantages balance each other out,” Norbert Koch explains. Together with researchers at the Berlin Humboldt University and the Georgia Institute of Technology in Atlanta, he and his team created such a hybrid semiconductor structure and studied its electronic and optical characteristics in detail. The scientists developed a new method that can turn the hybrid material into an especially efficient light emitter. They made their hybrid semiconductor out of a combination of zinc oxide – an inorganic crystalline semiconductor material – and oligophenylene. This robust organic substance is also semiconducting, and was specially designed and synthesised by chemist Stefan Hecht at Humboldt University. It has a ladder-like molecular structure of benzene rings joined together by additional carbon atoms.

“First, we used optical excitation to produce a large number of electron–hole pairs in the zinc oxide, and then transferred them into the organic material,” Koch reports. The trouble is, there is a large offset between the energy levels of the two materials. “So, while a lot of excitons travel from the inorganic semiconductor into the organic one, a great deal of their excitation energy is lost at the interface with no emittance,” says Koch. The light yield is therefore meagre and inadequate for technical application.

### A donor material gives the efficiency a big boost

The researchers employed a trick to solve the problem. They inserted a thin layer of a third material between the two semiconductors: a so-called donor material that changes the electronic structure of the zinc oxide in a targeted manner. “Our American partners at Georgia Tech

had already developed suitable molecules for this,” Koch continues. “Under the donor’s influence, the energy levels in the inorganic and organic semiconductors align with each other.” There was a manifold increase in the number of excitons contributing towards light emission after migrating from the zinc oxide to oligophenylene, compared to the number the researchers measured without a donor layer. The efficiency – the amount of excitation energy converted to light – consequently rose to about 35 per cent. “The results show that our method works well,” Norbert Koch is pleased to report. Yet the materials researcher wants to take it a step further: “We have understood the physical bases, and now we want to achieve 100 per cent efficiency,” he states his goal. Koch and his team are currently working on this. “Our idea is to add another semiconductor

that could prevent the non-emitting energy loss entirely,” Koch states. “Perhaps one day such a multihybrid material could be used to build LEDs that produce light at very high intensity of just about any desirable colour – and whose intensity could still be modulated at high frequency.” This would be a huge advancement in technical applications such as high-speed fibre-optic data transmission and processing, or the integration of electronic and photonic logic circuits.

rb

Nature Communications 6, 6754 (DOI: 10.1038/ncomms7754): Efficient light emission from inorganic and organic semiconductor hybrid structures by energy-level tuning; R. Schlesinger, F. Bianchi, S. Blumstengel, C. Christodoulou, R. Ovsyannikov, B. Kobin, K. Moudgil, S. Barlow, S. Hecht, S.R. Marder, F. Henneberger and N. Koch

## A MICROBATTERY UNDER THE X-RAY MICROSCOPE

Scientists of the Max Planck Institute for Solid State Research used **scanning transmission X-ray microscopy (STXM)** at BESSY II to investigate the ageing processes of lithium-ion batteries. Their results pave the way towards longer-lasting energy stores.

The way a lithium-ion battery works is actually quite simple. Its negative electrode is a lithium-graphite structure that gives off electrons, which then supply the mobile device with energy. After they have done their work, the negatively charged electrons are captured by positively charged iron ions in a second electrode made of lithium iron phosphate. If this were the whole story, then the two electrodes – the positive lithium iron phosphate electrode and the negative lithium-graphite electrode – would eventually become electrically charged. But, inside the battery, positively charged lithium ions migrate from the negative electrode to the positive one, thus balancing out the flow of electrons. When the battery is flat, we connect it to a power source that drives all of these reactions in the reverse direction. The iron ions give off electrons which flow through the external circuit back to the graphite where they are reabsorbed. The lithium ions also flow back to the negative electrode, again preventing the two electrodes from becoming electrically charged.

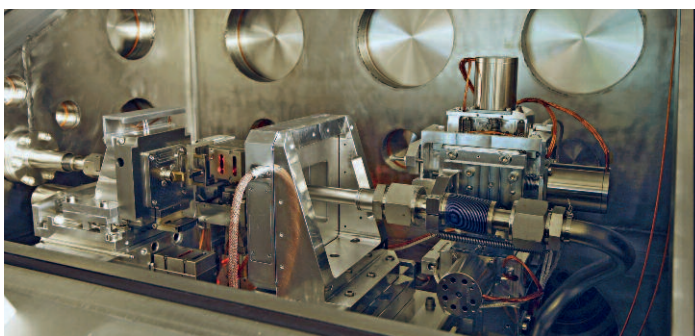

Analysis of the charge/discharge process on lithium-ion batteries conducted at the MAXYMUS station operated by HZB and the Max Planck Society, permanently installed on undulator beamline UE46 at BESSY II.

### Complex structures complicate analysis

While investigating the ageing processes that ultimately reduce a battery’s capacity over time, the Max Planck researchers led by Joachim Maier discovered a major obstacle at the lithium iron phosphate electrode. “It consists of millions of tiny crystals that differ in size, point in differ-



The internal processes taking place during charging and discharging of lithium-ion batteries are of great interest both to science and to the telecommunications and automotive industry.

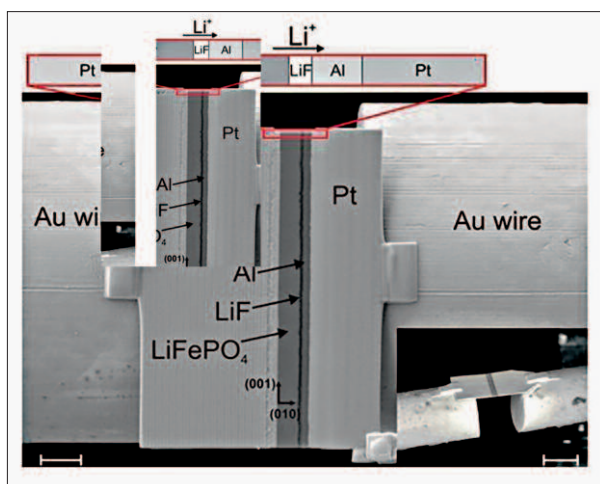

SEM image of the micrometer-sized battery: The all-solid-state thin-film battery cell is fixed between the ends of two free-standing gold wires. During electrochemical delithiation the electron is transported to the left platinum contact, while the lithium ion is transported through the electrolyte to the aluminium anode forming a lithium-aluminium alloy there. The small inset picture shows a side view of a similar thin-film battery cell. Scale bar: 2  $\mu\text{m}$  for the big SEM image, 10  $\mu\text{m}$  for the small inset.

ent directions in the electrode, and even differ in composition,” explains the materials scientist Robert Usiskin, who works in Joachim Maier’s group. In such a complex system, the chances of successful analysis are small. So instead, the researchers constructed a radically simplified electrode that consists of a single, tiny crystal of lithium iron phosphate. It is a mere 16-thousandths of a millimetre long, one-thousandth of a millimetre wide and 0.2-thousandths of a millimetre high. The researchers studied on this microelectrode how fast lithium ions migrate into it during discharge and out of it during charging, and how many even fit into it in the first place. These values define how quickly such a battery can deliver and absorb energy.

It also reveals how much energy it will store.

The trouble is, the microelectrode is much too small to observe by conventional methods. Gisela Schütz of the Max Planck Institute for Intelligent Systems referred the colleagues to the HZB, since processes in such tiny structures can be ideally observed using scanning transmission X-ray microscopy (STXM) at BESSY II. The X-ray beam scans the crystal, measuring how many trivalent and how many bi-

valent iron ions exist at each site. STXM shoots a sequence of images of the charging process while the bivalent iron ions each give off one electron to become trivalent iron ions as the battery charges.

#### Simultaneous start at multiple sites

On these pictures from the X-ray microscope, the researchers saw astonishing structures: “The iron ions don’t give off electrons along a surface boundary, rather they start the reaction simultaneously at several adjacent sites,” explains Robert Usiskin. Starting from these points, the reaction runs inwards into the crystal. This produces tiny nano-needles of trivalent iron cations, residing separately alongside a number of bivalent iron cations. At the same time, the lithium ions flow out of the crystal to balance the charge. The crystal thus loses mass and shrinks a little. This effect is much more prominent in the longitudinal direction than across the width or height. The mechanical strain causes the crystal to crack between the needles of trivalent iron cations. “These cracks can be clearly seen in the STXM images,” Robert Usiskin reports. Over time, the cracks damage the electrode and consequently reduce the battery’s capacity. Were a manufacturer to use smaller lithium iron phosphate crystals for the positive electrode, this effect could be reduced and the battery would age slower. While the manufacturers already knew this before the STXM experiments, now that the researchers have described the exact processes, they can provide better ageing protection through a more targeted choice of crystals for the electrode.

rk

Nature Communications, 6:6045 (DOI: 10.1038/ncomms7045): Phase evolution in single-crystalline LiFePO<sub>4</sub> followed by in situ scanning X-ray microscopy of a micrometre-sized battery; N. Ohmer, B. Fenk, D. Samuelis, C.-C. Chen, J. Maier, M. Weigand, E. Goering and G. Schütz

## NEUTRON IMAGES OF HYDROGEN STORES

There is a lot of application potential for hydrogen storage systems based on hydride-graphite composites (HGC). An international team of researchers has for the first time visualised the **formation and growth of active regions** in these compounds in operando, i.e. while the system is working.

The use of renewable energy sources is becoming increasingly important if we are ever to meet the climate policy targets. It is equally important then, to develop eco-friendly technologies to store our cleanly generated energy. Hydrogen is a versatile energy carrier, but we still need to find efficient solutions for storing it. Metal hydrides have received the most attention from researchers in recent years for their high storage capacities. Many hydride-forming metal alloys are currently known, but only few of them have made it into commercial use so far.

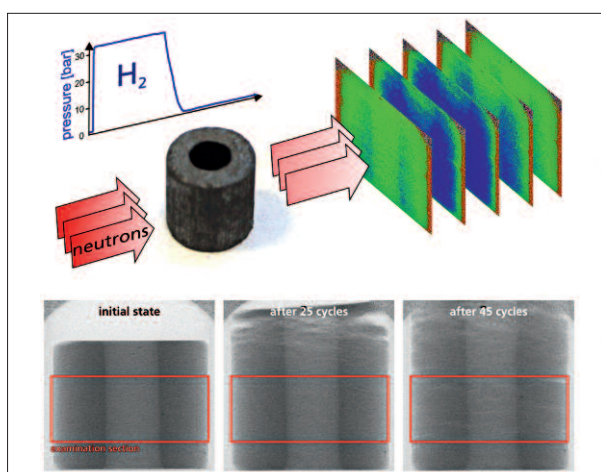

Neutron radiography of a Hydralloy®-based hydride-graphite composite with 5 wt.% expanded natural graphite in its initial state, after 25 and 45 hydrogenation cycles (dehydrogenated state). The examination section is highlighted.

“That was why we investigated a composite of natural graphite and a titanium-manganese alloy known as Hydralloy® C52,” says Dr. Ingo Manke of the Institute for Applied Materials Research at HZB who, together with his colleague Dr. Nikolay Kardjilov, oversaw the research team’s experiments at the neutron source BER II. “Once we know more about their properties, these versatile hydrogen storage systems could one day be used for storing excess energy from photovoltaic systems and wind turbines, as well as in fuel cell vehicles.”

### Active regions increase with operating cycles

In a neutron imaging experiment, the researchers studied both the activation behaviour and the operational performance of the material. Prior to the experiment, the HGC was activated by pretreating it at 125 °C in a low-pressure hydrogen atmosphere (less than 5 bar) in which no hydrogenation takes place. Next, the storage material had to go through a number of hydrogenation/dehydrogenation cycles until it reached full sorption capacity. Active regions within the HGC appeared to be statistically distributed, while the rest of the HGC volume remained inactive. Furthermore, the active regions grew in size with the number of cycles, probably due to locally elevated temperatures. In the final state, the active regions were distributed over the entire HGC volume. During the activation phase, the volume of the HGC continuously swells, due to lattice expansion of the hydrogen-absorbing material. In the final, fully activated state, there is no longer any significant increase in overall swelling.

### High heat conductivity allows rapid charging dynamics

In the second part of the experiment, the fully activated HGC was put through more hydrogenation/dehydrogenation cycles. Using neutron radiography, the researchers watched the material go through fast and slow hydrogenation and dehydrogenation processes. Reaction fronts became clearly discernible inside the HGC. They start at the container wall, where the heat transfer is fastest. “The high thermal conductivity of the hydride-graphite composite allows rapid temperature equalisation. Thus very fast charging and discharging dynamics of less than one minute can be achieved,” explains Dr. Nikolay Kardjilov. The formation and growth of active sites in the hydride-graphite composites were visualised for the first time in these experiments. Further experiments will concentrate on the influence of various hydrogenation/dehydrogenation rates and on the swelling of the storage material.

Journal of Power Sources 277, 360-369, (DOI: 10.1016/j.jpowsour.2014.12.011): In operando visualization of hydride-graphite composites during cyclic hydrogenation by high-res neutron imaging; C. Pohlmann et al.

## WHAT MAKES CATALYSTS EFFICIENT?

While searching for an **efficient catalyst for splitting water** into hydrogen and oxygen, scientists of Freie Universität Berlin studied at HZB whether the reaction takes place preferentially on the surface or within the bulk volume of a catalyst material.

**H**ydrogen could be used as an energy carrier for a sustainable energy supply, but so far it takes too much energy to produce the element on a large enough scale. Accordingly, the search is on for efficient, eco-friendly methods of producing hydrogen and other low-carbon-content fuels. One of the big players here is water oxidation driven by light or electricity. The aim is to develop a stable catalytic system with a particularly high turnover rate and low electric losses.

### X-ray spectroscopy reveals atomic structural changes

Prof. Dr. Holger Dau's group investigated whether catalytic functions are fulfilled on the outer surface or within the bulk volume of a catalyst material. The answer essentially



Researchers studied materials and processes at HZB that could make even higher-efficiency catalysts for splitting water by sunlight.

decides whether it is better to manufacture a catalyst with a crystalline surface or with its entire mass in an amorphous, quasi-porous state. The study focussed on the cobalt phosphate compound pakhomovskiyite (Pak), starting with its crystalline form.

The team used X-ray spectroscopy to observe the full process of converting Pak's atomic structure. They applied microcrystalline Pak onto an electrode and then applied a positive voltage, causing the crystal to transform completely over several hours into amorphous, phosphate-containing cobalt oxide. This consists of catalytic oxide clusters in an atomically porous environment with embedded water layers. In the transformation process, the overall catalytic activity increases significantly. "While the catalytic processes first prevail on the surface, breakdown of the crystalline order later leads to stronger reactivity in the volume of the hydrated oxide," explains Prof. Holger Dau. "For developing future-generation catalysts, it is important to know that both crystallites with a large surface area, and completely non-crystalline, amorphous oxides can bring specific advantages as catalyst materials."

### Reaction migrates inward

From the results, the research team is now certain that, in order to achieve efficient results when oxidising water with an insoluble catalyst, they must consider catalysis both on the surface and inside the volume of the material. This includes the dynamic restructuring and transformation of the catalyst material during the reaction. The researchers recommend further experiments to better determine the characteristics and rate of restructuring that are influenced by factors such as the (crystalline) structure and reaction conditions (pH, electrical potential and temperature). For catalysis research, the results clearly show that efficiency increases are possible. In future studies of new catalysts, the team of Prof. Holger Dau will therefore be focussing not only on changes in crystalline lattice structure but also the conversion into amorphous structures.

ve

Angew. Chem. 2015, 127, 2502–2506 (DOI: 10.1002/ange.201409333): Heterogeneous Water Oxidation: Surface Activity versus Amorphization Activation in Cobalt Phosphate Catalysts; D. González-Flores, I. Sánchez, I. Zaharieva, K. Klingan, J. Heidkamp, P. Chernev, P. W. Menezes, M. Driess, H. Dau and M. L. Montero

## BETTER BATTERIES WITH NANOPORES

Lithium-sulphur batteries theoretically have a **high charge capacity**, but they cannot be used in practice yet, since they degrade after only a few charge cycles. A scientist of the University of Hamburg conducted studies at HZB as to how the degradation process can be stopped.

**M**aterials scientist Simone Mascotto is practically a regular at HZB. For each visit, he travels the nearly 300-kilometre stretch from Hamburg to Berlin by train, and not by electric car, for one obvious reason: the car would only make it half way at most before coming to a halt, because the present-day lithium-ion battery would be drained by then. To overcome exactly this limitation, Mascotto is researching into carbon materials featuring nanopores that could be used as electrodes in lithium-sulphur batteries. Lithium-sulphur batteries can store many times more energy than the lithium-ion batteries powering our electric cars, smart phones and cameras these days.

When a lithium-sulphur battery is used, say, to drive an electric motor, electrons flow out from one electrode, through an external circuit, and back in to the other electrode. At the same time, positively charged lithium ions travel between the electrodes in the same direction, but instead taking a direct route through the battery itself. As they arrive, they combine with the sulphur in the electrode to form lithium polysulphides. During charging, these processes are reversed. Unfortunately, as the battery discharges during use, the lithium polysulphides inside dissolve and migrate away from the electrode. After only a few charge cycles, there is no available sulphur left, and the electrode is spent. Mascotto could indeed make the trip from Hamburg to Berlin on one such battery charge without stopping to recharge, but would then have to replace the expensive battery after only a few trips. Accordingly, he wants to fix the sulphur migration problem by locking the lithium polysulphides into the nanopores of a carbon material.

### Preventing sulphur migration

“If it works, a lithium-sulphur battery should be able to be recharged more than a thousand times,” Mascotto explains. He produces the nanoporous carbon material in a refined process in Hamburg. But he can only tell how good an electrode the substance makes by examining its exact structure: How big are the pores in reality, how are they distributed, how big is the total surface area for the sulphur to latch onto, and how well does the material conduct electricity?



Low battery capacities are still an impediment to electric vehicle sales. This could change with lithium-sulphur batteries.

Mascotto obtained a number of answers to these questions by placing the nanoporous carbon into a neutron beam for four hours at the Berlin research reactor BER II. For the study, the researcher filled liquid para-xylene into the pores, which scatters the neutron beams coming in at a flat angle in the exact same way as the carbon material. While the empty pores in the material can be clearly seen in the scatter curves, they disappear as soon as they are filled with para-xylene. The results of this elaborate experiment, which can only be performed at BER II, reveal the structure of the material in very high detail. A quarter of the entire surface area presents relatively large pores of about ten-millionths of a millimetre, or ten nanometres, in size. Between these are many much smaller pores of only one nanometre in diameter, which fill up before the larger pores do. The analyses thus reveal the exact structure of the electrode material which Simone Mascotto now wants to modify in order to optimise it. In further experiments, he will find out what structures and arrangements of pores yield the best results. This might just deliver the breakthrough in electromobility we have been waiting for. *rk*

Carbon, (DOI: 10.1016/j.carbon.2014.10.086): Poly(ionic liquid)-derived nanoporous carbon analyzed by combination of gas physisorption and small-angle neutron scattering: S. Mascotto et. al



## LITTLE HELPERS FOR WATER ELECTROLYSIS

**Storing energy in hydrogen** obtained by water electrolysis is considered an important component of the future energy system. Nanoparticles of a new kind with excellent properties could help make an economic breakthrough in this method.

**R**enewable energy sources present a problem for network operators: since the amount of electricity generated from wind and sun varies greatly with the weather, they need technologies to store the electricity at times when the demand is low. Water electrolysis is an especially promising solution for this, where the electrical energy splits water into hydrogen and oxygen. The energy bound in the hydrogen can be converted back into electricity in gas plants, or be used for driving fuel-cell-powered

a material that makes the electrolytic oxidation of water much more efficient. The research team also used experimental set-ups at the HZB to look deep within the innovative material.

The basis for the new, highly effective catalyst material is nickel oxide, which Dina Fattakhova-Rohlfing and her team doped with iron atoms and put through a specially developed synthetic process. The chemists dissolved the material in tert-butanol and heated it to 200 degrees

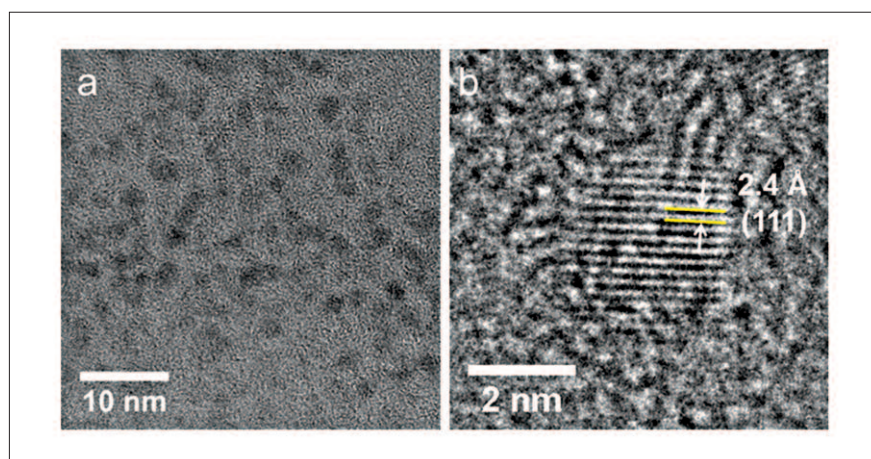

TEM images of the  $\text{Fe}_{0.1}\text{Ni}_{0.9}\text{O}$  nanoparticles (NP-10%): (a) overview of the nanoparticles dispersed on the TEM grid. (b) HRTEM image of a single  $\text{Fe}_{0.1}\text{Ni}_{0.9}\text{O}$  nanoparticle.

cars or as a raw material in the chemicals industry. However, the electrolytic process for splitting water requires a catalyst to spur on the chemical reactions. Of the two processes taking place in water electrolysis – reduction into hydrogen and oxidation into oxygen – the latter is the most problematic for the chemists. The most suitable compounds for accelerating it tend to contain rare metals such as ruthenium or iridium, making water electrolysis expensive. Accordingly, the researchers are looking for cheaper catalyst materials.

### HZB gives deep insights into materials

“The chemical production of oxygen is the limiting factor in the reduction chain of water electrolysis,” says Prof. Dr. Dina Fattakhova-Rohlfing. Together with colleague researchers from Düsseldorf and Berlin, the chemist at Ludwig-Maximilians-Universität München has developed

Celsius for about 20 hours in the laboratory oven. As a result, they obtained incredibly small nickel- and iron-containing particles, some less than two nanometres in diameter.

### Nanoparticles increase the reactive surface

These little helpers pack a punch. Because they are so small, for their minimal volume, they have an enormous surface area which has a very strong catalytic action. “In water electrolysis, the iron-nickel nanoparticles are around ten times more effective than the precious metal compounds used so far,” says Fattakhova-Rohlfing. Apart from their tiny scale, the particles’ highly crystalline character also helps. They are furthermore extremely stable: even after many hundreds of oxidation cycles, the researchers detected no remarkable wearing of the material.

To analyse the exact structure of the extraordinary nanoparticles, as well as their content and distribution of iron atoms, the scientists used an X-ray electron spectrometer at HZB. “This method is one of the few experimental methods that successfully resolves the immediate environment of individual atoms,” Fattakhova-Rohlfing explains. “So we were able to elucidate the structure of the particles in full.” The team of Munich scientists collaborated closely with the research groups of Dr. Ivelina Zaharieva, Biophysics and Photosynthesis in the Institute of Experimental Physics of Freie Universität Berlin, and Prof. Christina Scheu of the Max-Planck-Institut für Eisenforschung in Düsseldorf. The results of the HZB experiments revealed an important structural detail of the material: during the synthesis of the nanoparticles, so-called metastable phases form to produce unusual compositions of iron and nickel – which in fact boost the catalytic action.

#### One method for many applications

Dina Fattakhova-Rohlfing sees the findings as a big step towards the high-efficiency, low-cost electrolysis of water – and thus towards the economically viable storage of renewably obtained electrical energy in hydrogen. The highly

active nanoparticles offer a good way to create different types of catalysts. The particles are easy to produce, good to process and versatile in application. Furthermore, they can be applied onto various electrode materials as thin, uniform layers, or can be integrated into porous structures as tiny crystallites. Little wonder that several industrial companies have already shown interest in the new catalyst material.

For the researchers led by Dina Fattakhova-Rohlfing, however, the work has just begun: “We want to produce similar particles with other systems and doping materials, test other synthetic processes and produce even smaller nanoparticles,” the Munich researcher says. She hopes this will increase the efficiency of water electrolysis even further.

*rb*

ACS Nano, Vol. 9, No. 5, 5180-5188 (DOI: 10.1021/acs.nano.5b00520): Iron-Doped Nickel Oxide Nanocrystals as Highly Efficient Electrocatalysts for Alkaline Water Splitting; K. Fominykh, P. Chernev, I. Zaharieva, J. Sicklinger, G. Stefanic, M. Döblinger, A. Müller, A. Pokharel, S. Böcklein, C. Scheu, T. Bein and D. Fattakhova-Rohlfing

## GOING FOR THE ACHILLES HEEL OF HIV

Scientists of Heidelberg University Hospital and the Prague Academy of Sciences have studied the **maturation process of the AIDS pathogen HIV**. Their results reveal new possibilities for combatting the autoimmune disease.

**E**ven dangerous viruses have a weak point in their life cycle, during the rest of which they are nigh invulnerable. Such an Achilles Heel for the Human Immunodeficiency Virus (HIV) is its maturation stage. After infecting a human cell, the virus forces the infected cell to mass-produce new viruses. New pathogens are created in the form of tiny spherules that while they contain all components of HIV, are quite harmless at first. While in this form, they cannot infect any other human cells or force them to produce new viruses. Only after an enzyme from the virus itself thoroughly rebuilds the spherule, turning it into the typical capsid-form of a mature virus, do the young pathogens become infectious. There are already several drugs available that block this virus enzyme called “HIV protease” and which can accord-

ingly be used in AIDS therapy. However, researchers are still groping in the dark trying to answer exactly how the complex rebuilding of the pathogen works. If we understood this process in greater detail, we could develop new active agents that attack the individual steps in this maturation process in a targeted manner, and thus put the pathogens out of action with new drugs.

#### Minute scale and unsynchronised maturation

Barbara Müller of the Department of Virology of Heidelberg University Hospital and her colleagues in Prague and Heidelberg have therefore good reason to take a closer look at how a freshly produced, still harmless spherule metamorphoses into a dangerous virus. “However, we still have a number of hurdles to overcome along the way,”

Barbara Müller explains. One of these hurdles is the tiny size of HIV, being only about 150 nanometres, or 0.15-thousandths of a millimetre in size. This is too small to see under an optical microscope, since the physical laws of light beams only allow them to resolve structures larger than about 200 nanometres. An electron microscope can resolve much smaller structures, but can only take static “snapshots”, making it sadly useless for observing a transformation process in detail. As if that were not enough, the thousands of budding viruses in the cell do not all develop simultaneously, rather each matures in its own time. So when researchers analyse the maturation of the virus using conventional biochemical methods, they observe a mixture of buds and viruses in various stages of development. This makes it very difficult to observe the actual transformation. But what if the researchers were to halt the development of all viruses while they were still in their spherical bud form? If they were then to release this blockade simultaneously, for all buds at once, then the viruses would mature synchronously, and one could then study them properly using established biochemical methods.

#### Important intermediate step studied at BESSY II

Jan Konvalinka and colleagues at the Institute of Organic Chemistry and Biochemistry of the Prague Academy of Sciences have developed such a synchronisation method. The starting point was an agent used as an HIV protease inhibitor drug. The Czech biochemists attached a second molecule onto it that is sensitive to blue light at 405 nanometre’s wavelength. A crystalline structural analysis using synchrotron radiation from BESSY II which the Czech researchers performed on Beamline 14.2 run by the Joint Berlin MX-Laboratory confirmed that this combined molecule tightly binds the HIV protease, thus blocking it. Only when the blue light is turned on does the active agent and its appendage quickly degrade, and thus end the protease blockade, thus triggering the maturation of all virus buds simultaneously.

Thanks to this development, Barbara Müller and colleagues at the Heidelberg laboratory were able to study the process using conventional biochemical methods. They first infected cell cultures with HIV and then added the blue-light-sensitive agent developed in Prague. Because this agent only blocks the maturation of the viruses, the buds develop completely normally. The researchers isolated these non-infectious young viruses and irradiated them with blue

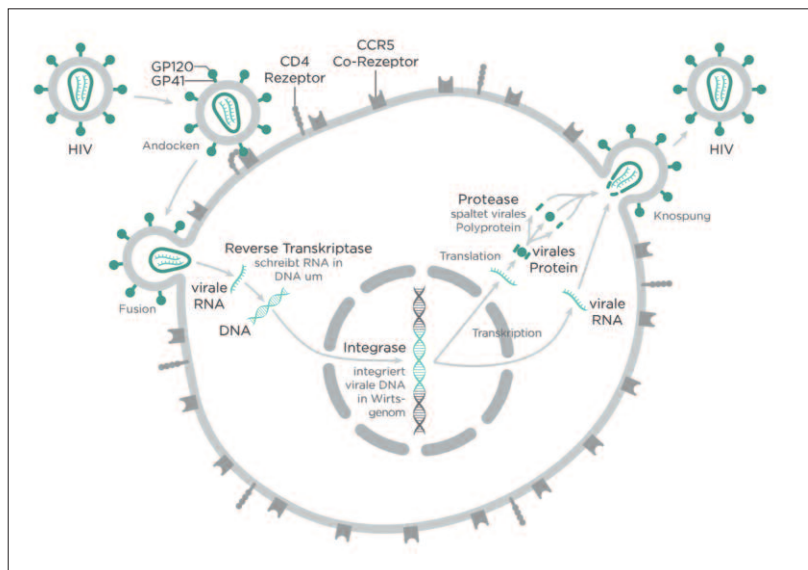

Schematic diagram of the replication cycle of HIV, which takes place thousands of times inside an infected cell. To develop new actives that block the HIV maturation process, scientists have studied the cycle at the highest possible resolution.

light. The active agent’s hold on the HIV protease instantly dropped by a factor of ten thousand, the results show. The blockade thus ended almost entirely after switching on the blue light, and the virus buds could therefore start to mature simultaneously. Using biochemical methods, the researchers then observed how the protease broke down the two existing structural proteins into smaller parts. Hans-Georg Kräusslich of Heidelberg University Hospital and his colleagues want to observe this process under, among other things, a novel fluorescence microscope developed by Nobel laureate Stefan Hell and colleagues of the Max Planck Institute of Biophysical Chemistry in Göttingen. Without infringing the resolution limit, certain tricks improve the resolution of this optical microscope to make the maturing viruses just visible. This could improve the chances of finding new active agents to block the HIV maturation process.

rk

Nature Communications, 6:6461 (DOI: 10.1038/ncomms7461): Triggering HIV polyprotein processing by light using rapid photo-degradation of a tight-binding protease inhibitor; J. Schimer, M. Pávová, M. Anders, P. Pachi, P. Sächsa, P. Cígler, J. Weber, P. Majer, P. Rezáková, H.-G. Kräusslich, B. Müller and J. Konvalinka

## INTRACELLULAR HEAVY TRANSPORT

An international research team has observed for the first time the **propagation of herpes viruses** inside the cell nucleus and their spread throughout the cell using X-ray microscopy and other methods at BESSY II. Using refined lenses, the researchers were able to view individual cell components such as the cell nucleus at a resolution of ten nanometres.

**H**erpes simplex viruses are spread worldwide; in Germany, more than 80 per cent of the population is infected by them. In order to understand the spread of the virus, cell biologists are studying the processes inside the infected cells. They are using a number of latest-generation observational methods for this. The X-ray microscope at the synchrotron BESSY II plays a key role, where Prof. Dr. Gerd Schneider and colleagues at the HZB Institute for Soft Matter and Functional Materials have now made structures visible that are only ten nanometres, a mere hundred-thousandth of a millimetre, in size. The scientists used refined lenses to achieve this resolution which, aside from HZB, only few other establishments in

Schematic of the stages of vesicle-mediated herpes virus capsid nuclear egress, consisting of primary envelopment by the nuclear egress complex at the inner nuclear membrane and fusion of the vesicle with the outer nuclear membrane, resulting in de-envelopment to release the capsid into the cytoplasm.

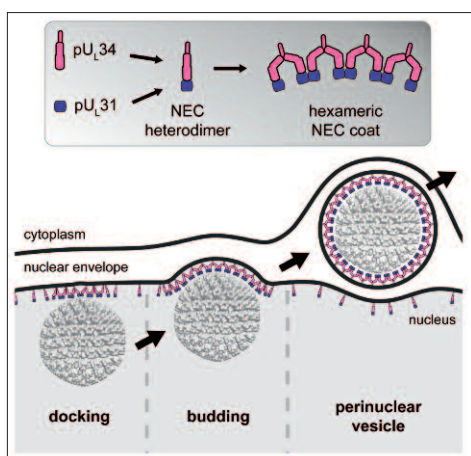

the world can offer. While the researchers can see particles ten times smaller still under an electron microscope, they can only do so if they slice the cells into ultra-thin sections first. “Our X-ray microscope, on the other hand, shines through whole cells,” Gerd Schneider describes the major advantage of this method.

This way, an international research group was able to observe cells infected with the herpes virus during an infection. “These tiny pathogens take a cell nucleus hostage and take command of it,” explains HZB researcher Dr. James McNally. Instead of controlling the processes in its cell,

the cell nucleus now produces virus particles from which new pathogens are assembled. However, the pathogen first has to get these relatively large particles through the double-wall membrane separating the nucleus from the rest of the cell. There are a series of pores in the nuclear membrane through which the nucleus is supplied with important molecules. “But these are only 30 nanometres large while a virus, by contrast, reaches a size of up to 200 nanometres,” Schneider describes the situation.

### Labelled proteins light the way

The pathogens solve the problem by exploiting a transport mechanism the nucleus otherwise uses to channel particles that are too big for the pores in the membrane. Cell biologists wanted to take a closer look at this process, which was discovered only a few years ago. “With our X-ray microscope, we see the membrane around the cell nucleus very clearly,” says Gerd Schneider. Thus, the researchers also discovered clues as to how the herpes viruses enclosed in the double-walled nuclear membrane manage to escape again. Analysing these “heavy transporters” in as much detail as possible, they wanted to know which proteins the viruses use to unlock the transport structures created during this process. “The high-resolution fluorescence microscope helps here,” explains James McNally. The researchers labelled individual proteins of the viruses with a fluorescent dye. Flashes of colour under the fluorescence microscope then revealed the respective proteins and their positions. Using this method, the researchers do not see the tiny structures directly, however, they can characterise them by comparing with the results of X-ray microscopy. Gaining an even more detailed view of the structures would then involve the electron microscope and other methods. With this combination of different methods, the researchers can now study the heavy transporters in great detail, which are important not only for the propagation of viruses, but apparently are also pivotal to many crucial processes in the cell. *rk*

Cell 163, 1692–1701 (DOI: 10.1016/j.cell.2015.11.029): Structural Basis of Vesicle Formation at the Inner Nuclear Membrane; C. Hagen et. al.

## METAL OXIDE SANDWICHES

A Franco-German cooperation has investigated a sandwich system of transition metal oxides at BESSY II. The scientists discovered a new option to control properties of the interface between the two layers. Their insights might help to **create novel forms of high Tc superconductivity**.

**S**andwich systems of thin-film transition metal oxides display surprising properties at their interfaces. In the case of the paradigmatic example of lanthanum-aluminate ( $\text{LaAlO}_3$ ) and strontium-titanate ( $\text{SrTiO}_3$ ), both materials are insulators and non-magnetic, while their interface has been observed to display ferromagnetism, high electrical conductivity and even superconductivity.

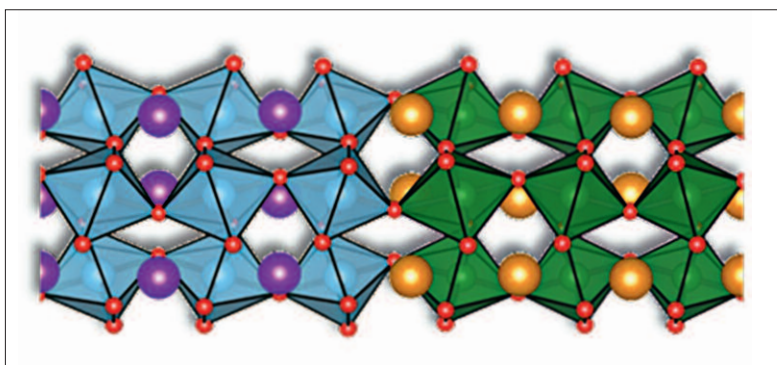

Sketch of the structure of both metal oxide layers. Interesting new properties can arise at the interface.

The team of Dr. Manuel Bibes, CNRS Thales at Palaiseau, France, in collaboration with scientists at HZB around Dr. Sergio Valencia and several European groups, devised a new approach to tailor interface properties. Together they designed a series of experiments at the synchrotron source BESSY II to shed more light on the emergence of such property changes, identifying a new “knob” for their control.

### Rare-earth elements influence charge transfer

The samples which the team of Manuel Bibes produced, consisted of a sandwich of two nanometre gadolinium-titanate ( $\text{GdTiO}_3$ ) and “R”-nickelate ( $\text{RNiO}_3$ ) films, where R is a rare-earth element. “We have been able to combine two very different transition metal oxides: whereas in the titanate, electrons in the chemical bonds are strongly localised around the ions, in the nickelate side these electrons are shared between nickel- and oxygen-ions, and

are thus highly covalent”, Manuel Bibes explains. When putting both materials together, some charge is transferred from the titanate layer to the nickelate one. They investigated this charge transfer process for samples containing different rare-earth elements in the nickelate layer such as lanthanum, neodymium and samarium at BESSY II.

Their results show that the charge transfer at the interface between the materials strongly depends on the rare earth element in the nickelate layer. Different rare-earth elements have different atomic radii (size). This modifies the interaction between the Ni and O atoms and the degree of “covalency” between Ni and O changes. This was already known, but now the scientists have observed that this also affects the charge transferred from the  $\text{GdTiO}_3$  to the nickelate film. “This is the key result”, Sergio Valencia from HZB explains. “We have found a new “knob”. Covalency, which is controlled by changing R, controls the charge transfer between the titanate and the nickelate.”

### Ferromagnetism observed, superconductivity still sought

Tuning the charge transfer in this way might allow controlling the formation of new interfacial phases too. For example, the scientists observed a new ferromagnetic phase at the interface. “Our work may help in the ongoing quest for cuprate-like superconductivity in nickelate heterostructures”, Valencia says. “We hope that this study will help to design better interfaces for exploring new exciting new phases of matter at interfaces between covalent materials”, Bibes adds. arXiv

Nature Physics, 12, 484-492 (DOI: 10.1038/nphys3627): Hybridization-controlled charge transfer and induced magnetism at correlated oxide interfaces; M. N. Grisolia, J. Varignon, G. Sanchez-Santolino, A. Arora, S. Valencia, M. Varela, R. Abrudan, E. Weschke, E. Schierle, J. E. Rault, J.-P. Rueff, A. Barthélémy, J. Santamaria and M. Bibes

## AN ENZYME CATALYST FOR CARBON DIOXIDE

A research team of Humboldt-Universität zu Berlin (HUB) made an atomic-scale study at BESSY II of how an **enzyme from a micro-organism converts carbon dioxide into carbon monoxide**. The new insights could deliver the blueprints for a technical catalyst.

For a biochemist such as Prof. Dr. Holger Dobbek of HUB, carbon dioxide is nothing more than a climate-harming waste product which he would very much like to convert into a valuable raw material. For example, one could remove one of the oxygen atoms from carbon dioxide to turn it into carbon monoxide. This may be toxic to humans, but it harbours far more energy than carbon dioxide. It can also be converted relatively easily into compounds such as acetic acid, which in turn can be used



Coal-fired power plants such as the one in Werdohl-Elverslinsen in North Rhine-Westphalia produce relatively large amounts of carbon dioxide. Researchers at HZB have taken the first step towards making a catalyst that could convert the polluting gas into carbon dioxide and acetic acid.

to produce many other hydrocarbons that would otherwise have to be made from crude oil.

Microorganisms in hot, carbon-monoxide-rich sources on the Southern Kuril islands to the north of Japan could help here. The bacteria convert carbon monoxide into carbon dioxide and live off the energy released in the process. They have an enzyme that helps them do this, at the centre of which are one nickel, four iron and four sulphur atoms. “With this enzyme, other bacteria species can convert carbon dioxide back into carbon monoxide,” reports Holger Dobbek. The chemicals industry is keenly interested in this since the conversion process has so far required a lot of

energy using conventional technical catalysts. A catalyst mimicking the bacterial enzyme could do this with far less energy consumption.

### Numerous experiments at BESSY II

To artificially create such a catalyst, however, one must first understand exactly how the enzyme works in the bacteria. Holger Dobbek and his colleagues Jochen Fesseler and Jae-Hun Jeoung have now made an important breakthrough at Beamline 14 at the synchrotron ring BESSY II. To analyse the structure of the enzyme in X-ray light from BESSY II, the enzyme has to exist in crystalline form. This means the large, complex protein molecules making up the enzyme must be arranged into a regular crystal lattice. A difficult preparation step, but the researchers were able to do it. Before crystallisation, they applied different quantities of CO<sub>2</sub> before allowing the conversion process to take place. They then snap-froze the enzyme with liquid nitrogen, pausing the reaction just as it was starting, and grew crystals from this stage. “In a great collaboration with Manfred Weiss and his colleagues from HZB, we studied our crystallised enzymes countless times there,” Holger Dobbek relates. Ultimately, the researchers saw every single atom at the centre of the enzyme in high resolution. The amazing result of these efforts can be seen in a snapshot taken just before the carbon dioxide gives off an oxygen atom: the carbon dioxide molecule sits with its carbon atom right up close to a nickel atom of the enzyme, while one of the two oxygen atoms is pushed close to one of the iron atoms. The normally straight carbon dioxide molecule bends so greatly in the enzyme that it finally drops the oxygen atom near the iron atom. With this precise information, there are better chances for constructing a low-cost catalyst that converts the waste product carbon dioxide into the valuable raw materials carbon monoxide and acetic acid.

*rk*

Angew. Chem. Int. Ed. 2015, 54, 8560–8564 (DOI: 10.1002/anie.201501778): How the [NiFe<sub>4</sub>S<sub>4</sub>] Cluster of CO Dehydrogenase Activates CO<sub>2</sub> and NCO; J. Fesseler, J.-H. Jeoung and H. Dobbek

## IMPRESSIVE PHOTOS OF SCIENCE

IN NOVEMBER 2015, 47 AMATEUR PHOTOGRAPHERS TOOK PART IN THE **SECOND HZB SCIENCE PHOTO-WALK**. THEIR PICTURES WERE PRESENTED IN A PHOTO COMPETITION.

Holger Fehsenfeld's picture "Weltraum" ("Space") enjoyed two successes: for the jury of five experts in art, photography and media, it was best out of nearly 200 submitted contestant photos. The 103 HZB employees who gave their vote for the public choice award picked it for third place. Fehsenfeld was one of the amateur photographers who, in November 2015, were granted an insight into a world that very few non-scientists get to see, let alone photograph. For about three hours, HZB employees guided the photographers to various research settings on the Adlershof campus. The highlight: BESSY II, a place where top research is conducted and which, it so happens,

offers great scope for creativity, as the visitors quickly recognised. Finally, the participants submitted their best pictures to the photo competition of the HZB Science Photo Walk. The jury of five judged a total of 192 photos, selected the 20 best themes from these and awarded three prizes. Isabel Wienold took 2nd place with her photo "Spirals", and Martin Brünger took 3rd place with "Scientist at Work III". HZB employees



"Weltraum" ("Space") is the title of the photo that won Holger Fehsenfeld 1st prize from the jury and 3rd place in the public choice award in the HZB Science Photowalk photo competition.

selected Hans Georg Conradis's work "Insights" for 1st place and Doris Krock's picture "The elephant" for 2nd place. The winning photos and best themes were subsequently exhibited in a vernissage at BESSY II.

## FROM EXCITED ATOMS TO FUNCTIONALITY

UNDER THE EU HORIZON 2020 PROGRAMME FOR RESEARCH AND INNOVATION, **ALEXANDER FÖHLISCH** HAS BEEN AWARDED AN ERC ADVANCED GRANT.



The European Research Council (ERC) promotes unconventional, trailblazing research and supports outstanding researchers. Alexander Föhlisch holds a joint appointment at the Institute for Physics and Astronomy of the University of Potsdam and at HZB. He is to receive a total of 2.5 million euros over a five-year period to support his work on highly selective methods of detection using synchrotron light and X-ray lasers. The new research project is named "Excited-State Dynam-

ics from Anti-Stokes and Non-Linear Resonant Inelastic X-Ray Scattering" (EDAX). Under this programme, Prof. Föhlisch will be studying how chemical reaction pathways and phase-transition behaviour can be probed using novel X-ray spectrographic methods. These will serve as a foundation for efficient energy conversion and future energy-efficient information technologies. The University of Potsdam is pushing ahead with cutting-edge research through the EDAX project and consolidating the rising success of the University in EU research programmes.

## NEW YOUNG INVESTIGATOR GROUP FOR SOLAR FUELS

AS OF THE BEGINNING OF 2016, **DR. KATHRIN AZIZ-LANGE** SET UP A HELMHOLTZ YOUNG INVESTIGATOR GROUP ADDRESSING THE TOPIC OF SOLAR FUELS AT HZB.

The Helmholtz Association has selected a total of 17 excellent young investigators to set up their own research groups out of a field of 250 international competitors at the end of October 2015. "We are pleased that Kathrin Aziz-Lange convinced the jury of her research plans in the highly competitive selection process, and that she will now expand the research on solar fuels at HZB," says Prof. Anke Kaysser-Pyzalla, scientific director of HZB.

Aziz-Lange is especially interested in the role of defects such as voids in the structures of novel systems of materials. These voids can lead to desirable as well as undesirable properties. Aziz-Lange wants to observe how voids originate in catalysts and light-absorbing materials.



## FREIGEIST FELLOWSHIPS FOR TWO SCIENTISTS AT HZB

THE VOLKSWAGEN FOUNDATION IS FUNDING THE RESEARCH OF **DR. ANNIKA BANDE** AND **DR. TRISTAN PETIT** FROM THE TEAM OF PROF. DR. EMAD AZIZ.



Dr. Tristan Petit and Dr. Annika Bande are supported by Freigeist Fellowships for their research projects at HZB.

With its Freigeist Fellowships, the VolkswagenStiftung is funding outstanding postdocs who are planning original research that transcends the boundaries of their own field. For his project on nanodiamond materials and nanocarbon, Dr. Tristan Petit was awarded a Freigeist Fellowship in 2015. The grant covers a five-year period and will enable him to establish his own research team. Following his doctoral studies, Dr. Tristan Petit joined the HZB team of Prof. Emad Aziz supported by a post-doctoral stipend from the Alexander von Humboldt Foundation. He had already investigated the surface modification of nanodiamonds while exploring their potential for biomedical applications during his doctoral research at the Diamond Sensors Laboratory (CEA) in Gif sur Yvette, France. Petit has since expanded his research interests. This is because nanodiamond materials can also exhibit catalytic effects, in particular when irradiated by sunlight. One dream is to develop synthetic nanodiamond materials for manufacturing solar fuels such as methane using sunlight and carbon dioxide, thereby storing solar energy chemically. Aziz and Petit are currently working on this project under the European DIACAT research programme.

Dr. Annika Bande had previously received a Freigeist Fellowship for her research at the

Institute of Methods for Material Development, which she used to set up her own group at HZB. The theoretical chemist's research focuses on ultrafast energy transfer processes. Central to her research is what is known as interatomic Coulombic decay (ICD) where an electronically excited state is produced within an atom. Upon returning to its ground state, the atom transfers its excess energy to a neighbouring atom or molecule through electronic Coulomb interactions. During this process, the electrons interact with each other even over long distances. As part of her theoretical work, Annika Bande was able to demonstrate that ICD must also take place in semiconductor nanocrystals called quantum dots. Bande and her team are hoping to furnish experimental evidence as part of her work at Emad Aziz's institute.

hs

## GERMAN SOLAR PRIZE FOR MARTHA LUX-STEINER

THE **EUROPEAN ASSOCIATION FOR RENEWABLE ENERGY (EUROSOLAR)** GAVE THE AWARD IN RECOGNITION OF HER LIFETIME OF WORK AND INVOLVEMENT IN RESEARCH AND EDUCATION.

Prof. Dr. Martha Lux-Steiner headed the Institute for Heterogeneous Materials Systems at Helmholtz-Zentrum Berlin until March 2016 and was



Professor of Physics at Freie Universität Berlin.

Over the course of her career, the renowned scientist has developed materials systems for solar cells, furthered technology transfer, involved herself in education, and supported junior scientists particularly, as her encomium set out. She has always pioneered new approaches, including starting a summer university programme in the Swiss Alps where students of architecture, economics and the natural sciences become absorbed in the practical and theoretical aspects of renewable energy.

## IMPORTANT APPOINTMENTS

**Prof. Dr. Gerd Schneider** accepted a W2-S "X-ray microscopy" professorship at the Department of Physics of Humboldt-Universität zu Berlin in April 2015. The professorship is associated with heading the work group "X-ray microscopy" at HZB.

**Prof. Dr. Emad Aziz** was promoted to full professor (German W3) at Freie Universität Berlin effective 1 July 2015. He previously held a junior professorship in the Department of Physics. Aziz heads the HZB Institute for Methods of Material Development and the JULiq Joint Lab operated concomitantly by HZB and Freie Universität Berlin.



## FIVE YEARS OF HZB SCHOOL LAB ALSO AT ADLERSHOF

TO GET SCHOOL PUPILS INTERESTED IN SCIENCE – FOR FIVE YEARS THIS HAS BEEN THE MISSION OF THE **HZB SCHOOL LAB** IN ADLERSHOF.



In October 2015, HZB's School Lab in Adlershof celebrated its fifth anniversary. Since its founding in October 2010, more than 5,500 school pupils have come to perform experiments at the premises on Magnusstrasse. For its anniversary, the HZB School Lab invited sixth-graders from its partner primary school, the Grünauer Schule, to come and do experiments. After a project day on the topic of shape-memory materials, there was further celebrating: with a small birthday stand and a cake for the guests and employees.

The School Lab offers two project days a week in Adlershof where the pupils can do their own experiments and receive answers to questions. Topics include solar energy, light and colour, interference and materials research. They are therefore,

just like the ones at HZB's School Lab in Berlin-Wannsee, clearly related to the research being done at HZB. The experiments and tasks are prepared to suit the respective target groups in the various grades – from primary to high school. "Many children and teenagers experience quite a different side of science at the School Lab; they have fun experimenting and become amazingly absorbed in their work," says Dr. Ulrike Witte, head of the HZB School Lab.

## DISTINCTIONS FOR RESEARCH AT HZB

IN 2015, **MANY SCIENTISTS** ONCE AGAIN RECEIVED AWARDS AND DISTINCTIONS FOR THEIR WORK.



**Frank Siewert** from the Institute for Nanometre Optics and Technology at HZB won the 2015 International Giovanni Sostero Award. He was honoured in particular for his contributions on the development of latest metrology for Synchrotron Optics. He has "pushed the limits of X-ray optics metrology to an unprecedented level and given collaborative and constructive support to the international community on metrology for X-ray optics" as the awarding committee pointed out.

Textures on Curved Magnetic Surfaces" at TU Chemnitz. For this, using a new combination of X-ray absorption tomography and photoemission spectroscopy, he studied three-dimensional magnetic structures with circular polarised radiation.



The 2015 Innovation Prize Synchrotron Radiation went to **Dr. Claudio Masciovecchio** of Elettra-Sincrotrone in Trieste. His work impressively demonstrated the possibilities of the world's first seeded free electron laser for soft X-rays, FERMI.



In December 2015, for the 25th time, the Friends of Helmholtz-Zentrum Berlin awarded the Ernst-Eckhard-Koch Prize for an outstanding doctoral thesis in the field of research with synchrotron radiation and the Innovation Prize Synchrotron Radiation. **Dr. Robert Streubel** was distinguished for his doctoral thesis "Imaging Spin

Textures on Curved Magnetic Surfaces" at TU Chemnitz. For this, using a new combination of X-ray absorption tomography and photoemission spectroscopy, he studied three-dimensional magnetic structures with circular polarised radiation.



**Dr. Steve Albrecht**, a post-doc working under Prof. Dr. Bernd Rech of the HZB Institute of Silicon Photovoltaics, was one of four scientists to receive the Carl-Ramsauer Prize 2015 of the Physikalische Gesellschaft zu Berlin. At a celebratory colloquium, he presented his work on the generation, recombination and extraction of charges in polymer-fullerene mixed solar cells.

# Organisation Chart HZB

Date November 2016, Rev. Oktober 28<sup>th</sup>, 2016 GZ



**Scientific Advisory Council**  
Chairwoman: Dr. U. Steigenberger

**General Meeting of Shareholders**  
(German Federation and State of Berlin)

**Supervisory Board**  
(Chairman: Dr. K. E. Huthmacher)

**Science and Technology Board**  
Chairwoman: Prof. Dr. S. Schorr

**Scientific Management**  
Prof. Dr. A. Kayser-Pyzalla

**Board of Directors**

**Administrative Management**  
Th. Frederking

**Works Council**  
Chairwoman: E. Lesner

**Renewable Energy**  
Speaker: Prof. Dr. B. Rech

**Silicon Photovoltaics**  
(Prof. Dr. B. Rech) EE-IS

**Solar Fuels**  
(Prof. Dr. R. van de Krol) EE-IF

**Competence Centre Photovoltaics Berlin**  
(Prof. Dr. R. Schlattmann) EE-IP

**Nanoscale Structures and Microscopic Analysis**  
(Dr. M. Wollgärtner) EE-ANSMA

**Interface Design**  
(Prof. Dr. M. Bär) EE-NI

**Nanooptical Concepts for PV**  
(Prof. Dr. M. Schmid) EE-NOPT

**Nano-SIPPE**  
(Prof. Dr. C. Becker) EE-NSIP

**Operando Characterization of Solar Fuel Materials**  
(Prof. Dr. K. Aziz-Lange) EE-NOC

**Perovskite Tandem Solar Cells**  
(Dr. S. Albrecht) EE-NPET

**Molecular Systems**  
(Prof. Dr. N. Koch) EE-GMS

**Energy Materials**  
Speaker: Prof. Dr. S. Schorr

**Soft Matter and Functional Materials**  
(Prof. Dr. M. Ballauff) EM-ISFM

**Applied Materials**  
(Prof. Dr. J. Banhart) EM-IAM

**Institute for Nanospectroscopy**  
(Prof. Dr. S. Raoux) EM-ISPEK

**Methods for Material Development**  
(Prof. Dr. E. F. Aziz) EM-IMM

**Functional Oxides for Energy Efficient Information Technologies**  
(Dr. C. Dubourdieu) EM-IFOX

**Structure and Dynamics of Energy Materials**  
(Prof. Dr. S. Schorr) EM-ASD

**Methods for Characterization of Transport Phenomena in Energy Materials**  
(Dr. K. Habicht) EM-AMCT

**Quantum Phenomena in Novel Materials**  
(Prof. Dr. B. Lake) EM-AQM

**Materials for Green Spintronics**  
(Prof. Dr. O. Rader) EM-AMGS

**Microstructure and residual stress analysis**  
(Prof. Dr. Ch. Genzel) EM-AME

**Catalysis for Energy**  
(Prof. R. Schlögl) EM-GKAT

**Berlin Joint Lab for Quantum Magnetism**  
(Prof. Dr. J. Reuther) EM-NQUAM

**Joint Macromolecular Crystallography Laboratory (Joint MX Lab)**

**Joint Lab for Structural Research (JLSR)**

**Joint Lab for Accelerator Physics (JLAP)**

**HEMCP Platform (HEMCP)**  
(Prof. Dr. R. Schlattmann)

**NEAT**  
(Dr. M. Russina)

**Research with Large Scale Infrastructures**  
Speaker: Prof. Dr. A. Föhlisch

**Methods and Instrumentation for Synchrotron Radiation Research**  
(Prof. Dr. A. Föhlisch) FG-ISRR

**Accelerator Physics**  
(Prof. Dr. A. Jankowiak) FG-IA

**SRF - Science and Technology**  
(Prof. Dr. J. Knobloch) FG-ISRF

**Nanometre Optics and Technology**  
(Prof. Dr. A. Erko\*) FG-INT

**Undulators**  
(Dr. J. Bahrndt) FG-AUND

**Simulations of ERL-Design**  
(Prof. A. Matveenko) FG-NSIMU

**Neutron Tomography**  
(Prof. Dr. W. Treimer) FG-GTOMO

**Functional Nanomaterials**  
(Prof. Dr. S. Eisebit) FG-GFN

**Uppsala-Berlin Joint Lab (UBJL)**

**Accelerator Physics (JLAP)**

**Dismantling of BER II**  
(Dr. S. Walzel / Dr. A. Rupp)

**Helmholtz Energy Materials Foundry (HEMF)**  
(Prof. Dr. R. van de Krol)

**User Platform**  
Speaker: Prof. Dr. A. Jankowiak

**User Coordination**  
(Dr. A. Vollmer) NP-ACO

**Operation Reactor BER II**  
(Dr. H. Krohn) NP-ABR

**Operation Accelerator-BESSY II**  
(Prof. Dr. A. Jankowiak) NP-ABS

**MLS Operation**  
(K. Bürkmann-Gehlein) S-MLS

**Protons for Therapy**  
(Dr. A. Denker) S-P.T

**Precision Gratings**  
(Dr. M. Lötgen) S-PG

**High Field Magnet**  
(Prof. Dr. B. Lake\*) NP-AHFM

**Scientific-Technical Infrastructure 1**  
(Dr. A. Rupp) NP-HI

**Technical User Support BER II**  
(Dr. A. Rupp) NP-AUN

**Sample Environments**  
(Dr. K. Kiefer) NP-ASE

**Procedural Management Decommissioning BER II**  
(Dr. A. Rupp) NP-APMD

**Scientific-Technical Infrastructure 2**  
(Dr. C. Jung) NP-HII

**Technical User Support BESSY II**  
(Dr. C. Jung) NP-AUP

**Technical Design**  
(L. Drescher) NP-ATD

**Manufacturing**  
(K. Tietz) NP-AMAN

**Administration**  
(U. Ewald) A

**Personnel und Social Matters**  
(M. Badel) A-PS

**Finances and Accounting**  
(J. Neumann) A-FR

**Purchasing and Materials Logistics**  
(D. Höcker) A-EM

**Facility Management**  
(N.N.) FM

**Planning and Construction**  
(F. Uschkoreit) FM-B

**Technical Services**  
(U. Grabe) FM-T

**Internal Services**  
(M. Nadolski) FM-I

**Chemicals and Special Wastes**  
(J. Beckmann) FM-C

**Waste**  
(J. Beckmann) S.Z.R.A.

**Security Services**  
(F. Delßenbeck) FM-O

**Information Technology**  
A. Finke IT

**Front Office and Helpdesk**  
(S. Vogt) IT-FH

**Services an Software**  
(L. Heintzel) IT-DS

**Experiment Control and Data Acquisition**  
(O. P. Sauer) IT-ED

**Infrastructure**  
(Dr. D. Herrendörfer) IT-IS

**Representatives for Safety and Radiation Service**  
(Th. Frederking)

Institute

Young Investigator Group  
Joint Laboratory

Joint Research Group

Working Group

Special Task

Committee

\* Acting Head

## Site map

The Lise-Meitner-Campus with the research neutron source BER II is located at the HZB Berlin-Wannsee site, whereas the Wilhelm-Conrad-Röntgen-Campus with the electron storage ring BESSY II is located at the HZB Berlin-Adlershof site.



## IMPRINT

**HZB Highlight Report 2015** of the Helmholtz-Zentrum Berlin für Materialien und Energie GmbH. Reprint only with the express permission of the publisher.  
Press date: July 2016

**Publisher:**  
Helmholtz-Zentrum Berlin, Hahn-Meitner-Platz 1, 14109 Berlin,  
Tel.: +49 (0)30 80 62-420 34

**Editors:**  
Dr. Ina Helms (ih, responsible), Hannes Schlender (hs, coordination), Antonia Rötger (arö), Silvia Zerbe (sz)  
E-mail: ina.helms@helmholtz-berlin.de, address as for publisher

**Publishing services & support:**  
n.k mediaconcept GbR, Obere Lagerstraße 38b,  
82178 Puchheim bei München, Tel.: +49 (0)89 80 90 83 33  
Managing directors: Klaus Dieter Krön, Christoph Neuschäffer

**Concept & realisation:**  
Christoph Neuschäffer (cn), Tel.: +49 (0)89 20 20 68 66

**Editorial staff:** Ralf Butscher (rb), Volker Eidems (ve), Roland Knauer (rk), Torsten Mertz (tm)

**Translation & lectorate:** Peter Gregg, Gill Elaine Schneider

**Design & layout:** Klaus Dieter Krön

**Picture editor:** Christoph Neuschäffer

**Picture editing:** Lothar Trutter

**Proofs:** Trumedia GmbH, Tattenbachstraße 19, 86179 Augsburg

**Print:**  
Elbe Druckerei Wittenberg GmbH, Breitscheidstraße 17a,  
06886 Lutherstadt Wittenberg  
Tel.: 03491 41 02 42, Fax: 03491 41 02 40  
E-mail: info@elbedruckerei.de, www.elbedruckerei.de

**Photo credits:** all photo rights remain with HZB, except for: front page: HZB/Michael Setzpfandt, page 2/3 HZB/Michael Fernahl, p. 7 HZB/Phil Dera, p. 8 HZB/C. Alonso Piney, p. 10 Thomas Splettstößer, p. 11 HZB/Florian Kronast, p. 12 HZB/Christoph Merschjann, p. 13 HZB/Guanchao Yin, p. 14 Zentrum für Sonnenenergie- und Wasserstoff-Forschung Baden-Württemberg, p. 15 HZB/Sebastian Fiechter, TTTNIS, p. 17 HZB/David Starr, p. 20 HZB/M. Setzpfandt, p. 21/22 MPI for the Physics of Light, p. 23 HZB/Steve Albrecht, p. 24 HZB/Phil Dera, VELUX Deutschland GmbH, p. 25 Syda Productions/fotolia, p. 26 HZB/Matthias May, p. 28 HZB/Volker Mai, p. 29 euroluftbild.de/Robert Grahn, p. 30 HZB/Dorothea Alber, p. 31 HZB/Marlen Paeplow, p. 34 Max Born Institute, p. 35 HZB/Karsten Holldack, p. 36 HZB/M. Fernahl, p. 37 HZB/Silvia Zerbe, p. 38 HZB/Julia Köszegi, p. 39 HZB/Heike Cords, p. 40 HZB/C. Alonso Piney, p. 41 HZB/Ingo Kniest, p. 45 dmitrimaruta/fotolia, MPI for Solid State Research/Ohmer, p. 46 Elsevier B.V., p. 47 vencav/fotolia, p. 48 Mihajlo Maricic/thinkstock, p. 49 LMU/ Dina Fattakhova-Rohlfing, p. 51 T. Splettstößer, p. 52 Christoph Hagen/Kyle C. Dent/Tzviya Zeev-Ben-Mordehai/Michael Grange/Jens B. Bosse, p. 53 Manuel Bibes, p. 54 Dr.G.Schmitz, p. 55 HZB/Holger Fehsenfeld, HZB/A. Rouvière, HZB/Andreas Kubatzki, p. 56 Volkswagen-Stiftung/Mirko Krenzel, www.rolandhorn.de/mail@rolandhorn.de, p. 57 HZB/Andreas Kubatzki, HZB/Phil Dera (2), htgrahn

## Contacts

### Lise-Meitner-Campus

Hahn-Meitner-Platz 1  
14109 Berlin  
Germany  
Tel.: +49 (0)30 8062 - 0  
Fax: +49 (0)30 8062 - 42181  
wannsee@helmholtz-berlin.de

### Wilhelm-Conrad-Röntgen-Campus

Albert-Einstein-Str. 15  
12489 Berlin  
Germany  
Tel.: +49 (0)30 8062 - 0  
Fax: +49 (0)30 8062 - 12990  
adlershof@helmholtz-berlin.de

### Institute Silicon Photovoltaics

Kekuléstr. 5  
12489 Berlin  
Germany  
Tel.: +49 (0)30 8062 - 0  
Fax: +49 (0)30 8062 - 41333  
E-IS-office@helmholtz-berlin.de

### PVcomB

Schwarzschildstr. 3  
12489 Berlin  
Germany  
Tel.: +49 (0)30 8062 - 0  
Fax: +49 (0)30 8062 - 15677  
info@helmholtz-berlin.de